

# Waikato District Council Water Supply Bylaw 2023

The Waikato District Council, in exercise of its powers and authorities conferred on it under the Local Government Act 2002 and its respective amendments, and all other relevant powers, makes the following bylaw.

## 1. Introduction

- 1.1. Waikato District Council (the Council) has the ability to make bylaws for the purposes of protecting, promoting and maintaining public health and safety.
- 1.2. Council has a duty under Section 17 of the Waikato River Settlement Act 2010, to have regard to Te Ture Whaimana o Te Awa o Waikato (the vision and strategy for the Waikato River). The vision is “for a future where a healthy Waikato River sustains abundant life and prosperous communities who, in turn, are all responsible for restoring and protecting the health and well-being of the Waikato River, and all it embraces, for generations to come”. In this regard, the Council recognizes the special, cultural, social, environmental and economic relationship of Waikato-Tainui with the Waikato River and the need to protect and restore the Waikato River.

*Advisory Note: the above introduction does not form part of this Bylaw and is intended to be read as an introductory note.*

## 2. Short Title, Commencement and Application

- 2.1. The Bylaw shall be known as the “Waikato District Council Water Supply Bylaw 2023”.
- 2.2. The Bylaw shall apply to the Waikato District.
- 2.3. The Bylaw shall come into force on 22 December 2023.

## 3. Scope

This Bylaw shall apply to the Waikato District (within the boundaries of the Waikato District pursuant to the Local Government Act 2002) and any land, building, work, or property under the control of the Council.

## 4. Purpose

- 4.1. The purposes of this Bylaw are:
  - (a) Promoting the efficient use of water and protecting against waste or

misuse of water from the water supply network.

- (b) Protecting the water supply and water supply network from pollution and contamination.
- (c) Managing and protecting from damage, misuse, or loss of land, structures and infrastructure associated with the water supply network.
- (d) Preventing the unauthorised use of land, structures or infrastructure associated with the water supply network.

## **5. Compliance with Other Acts and Codes**

This Bylaw is made under the authority of the Local Government Act 2002 for the supply of water to its customers in its capacity as a Water Supply Authority. The supply and sale of water by the Council is subject to:

- (a) Statutory Acts and Regulations, including.
  - i. Building Act 2004.
  - ii. Fire and Emergency Act 2017.
  - iii. Local Government (Rating) Act 2002.
  - iv. Local Government Act 2002.
  - v. Resource Management Act 1991.
  - vi. Water Services Regulator Act 2020.
  - vii. Water Services Act 2021.
  - viii. Water Services Entities Act 2022.
  - ix. Te Ture Whaimana – the Vision and Strategy for the Waikato and Waipā Rivers.
- (b) This bylaw is subject to the relevant Codes and Standards, including:
  - i. Water Services (Drinking Water Standards for New Zealand) Regulations 2022.
  - ii. Drinking Water Quality Assurance Rules 2022.
  - iii. OIML R49: Water meters intended for the metering of cold potable

water and hot water. Part 1: Metrological and technical requirements; Part 2: Test methods and Part 3: Test report format.

- iv. SNZ PAS 4509: 2008 New Zealand Fire Service Fire Fighting Water Supplies Code of Practice.
- v. NZS 4503:2005 Hand operated fire-fighting equipment.
- vi. NZS 4517:2010 Fire sprinkler systems for houses.
- vii. NZS 4515:2009 Fire sprinkler systems for life safety in sleeping occupancies (up to 2000 square meters).
- viii. NZS 4541:2020 Automatic fire sprinkler systems.
- ix. Backflow Prevention for Drinking Water Suppliers Code of Practice 2006, Water New Zealand.
- x. Water Meter Code of Practice 2003, Water New Zealand.
- xi. Resource Management (National Environmental Standards for Sources of Human Drinking Water) Regulations 2007.
- xii. Waikato Regional Infrastructure Technical Specification.
- xiii. National Engineering Design Standards.

## **6. Interpretation**

- 6.1. When interpreting this Bylaw, use the definitions set out in clause 7 unless the context requires otherwise. Where reference is made in this Bylaw to any repealed enactment, such reference should be taken as a reference to its replacement.
- 6.2. For the purpose of this Bylaw, the word 'shall' refers to requirements that are mandatory for compliance with this Bylaw, while the word 'should' refers to practices that are advised or recommended.

## **7. Definitions**

- 7.1. For the purposes of this Bylaw, unless inconsistent with the context, the following definitions apply:

### **Advisory Note**

A note which further explains a Bylaw clause but does not form part of the Bylaw.

<b>Air Gap</b>	A vertical air gap between the outlet of the water supply fitting which fills a storage tank, and the highest overflow water level of that storage tank.
<b>Approved</b>	Approved in writing by the Council, either by an authorised officer of the Council or by resolution of the Council.
<b>Authorised Agent</b>	Any person authorised or appointed by the Council to do anything in respect of the water supply network.
<b>Authorised Officer</b>	Any officer of the Council or other person authorised under the Local Government Act 2002 and authorised by the Council to administer and enforce its Bylaws.
<b>Auxiliary Supply</b>	A water supply, other than the Council’s system, on or available to a Customer system. These auxiliary supplies may include water from another provider’s public potable water supply or any natural source(s) such as a well, spring, river, stream, or “used waters” or “industrial fluids.”
<b>Backflow</b>	The unplanned reversal of flow of water or mixtures of water and contaminants into the water supply network.
<b>Backflow Device</b>	Backflow device or air gap that is designed to prevent the return of flow into the Council’s water supply network. These devices can include non-return valves, reduce pressure zone devices, and double check valves.
<b>Boundary</b>	Legal boundary of the site, or in the case of more than one premise on a site, it is defined by the notional boundary of a complying unit site area.
<b>Catchment</b>	An area of land which drains to a waterbody from where a public water supply is drawn.

<b>Commercial Use</b>	<p>The use of land and buildings for the display, offering, provision, sale or hire of goods, equipment or services and includes shops, markets, showrooms, restaurants, cafes, takeaway food bars, professional, commercial and administration offices, service stations, motor vehicle sales, visitor accommodation, the sale of liquor and parking areas associated with any of the above.</p> <div style="border: 1px solid black; padding: 5px; margin-top: 10px;"> <p><i>Advisory Note: Commercial components of retirement villages will be metered and classified as commercial activity.</i></p> </div>
<b>Connection</b>	<p>The valve, meter and associated fittings installed and maintained by the Council on the service pipe or at the point of supply.</p>
<b>Council</b>	<p>The Waikato District Council and includes an officer authorised to exercise the authority of the Council.</p>
<b>Customer</b>	<p>A person who has obtained the right to use or direct the manner of use of water supplied by the Council to any premises.</p>
<b>Domestic Water Use</b>	<p>Water taken and used for the purpose of providing for individual household use and for human drinking and sanitation needs and excludes any commercial or industrial use.</p>
<b>Development contribution</b>	<p>As defined in the Local Government Act 2002 and the relevant Waikato District Council Development Contributions Policy.</p>
<b>District</b>	<p>The Waikato District.</p>
<b>Extraordinary Supply</b>	<p>A category of on demand supply used for extraordinary use including all purposes for which water is supplied, other than an ordinary supply, and which may be subject to specific conditions and limitations.</p>
<b>Extraordinary Use</b>	<p>Any use of water which is outside of ordinary use and which may be subject to specific conditions and limitations including but not limited to water</p>

alerts and emergency provisions. This applies to the following water users:

- (a) Residential properties with spas, swimming pools or collapsible pools in excess of 6 cubic metres capacity;
- (b) Residential properties with fixed garden irrigation systems;
- (c) Commercial or business premises (including home-based commercial activities);
- (d) Industrial premises.
- (e) Any properties at which agricultural, horticultural or viticultural land use is occurring;
- (f) Lifestyle blocks (rural supplies);
- (g) Fire protection systems other than sprinkler systems installed to comply with NZS 4517;
- (h) Outside of Waikato District customers (supply to, or within another local authority);
- (i) Temporary suppliers;
- (j) Any other property found by Council to be using water above 15m<sup>3</sup>/day (a consent from the Waikato Regional Council is required);
- (k) Water carriers;
- (l) Any other auxiliary supply.

**Fees and Charges**

The fees and charges for water supply set by the Council.

**Fire Main Supply**

A category of supply from pipework installed for the purpose of fire protection only.

<b>Individual Customer Agreement</b>	An agreement between the Council and a water user that outlines both parties' rights and responsibilities for the supply and use of water.
<b>Isolation Valve</b>	The valve at the Customer end of the service pipe used to control and/or isolate the supply. This is also known as the service valve or toby.
<b>Level of Service</b>	The measurable performance standards on the basis of which the Council undertakes to supply water to its Customers.
<b>NZS</b>	New Zealand Standard.
<b>On Demand Supply</b>	A supply which is available on demand direct from the point of supply, subject to the agreed level of service.
<b>On Demand Water Supply Area</b>	An area serviced by a Council owned reticulated water supply network as defined in Schedule 3: Water Supply Area Maps, that is intended to supply water to Customers via on demand supplies with firefighting capability.
<b>Ordinary Supply</b>	A category of on demand supply used solely for domestic purposes, excluding any identified extraordinary water use.
<b>Owner</b>	The person or entity having legal ownership of the premises receiving a supply of water from the Council.
<b>Occupier</b>	The person or legal entity having a legal right to occupy, use all or part of the premises receiving a supply of water from the Council that includes a tenant, lessee, licensee, manager, foreperson or any other person acting in the general management of any premises.
<b>Permit</b>	A permit or written authority issued by an authorised officer.
<b>Person</b>	An individual, corporation sole, or a body of persons whether corporate or otherwise.

**Point of Supply** The point on the water pipe leading from the water main to the premises, which marks the boundary of responsibility between the Customer and the Council.

**Potable Water** Water that does not contain or exhibit any determinants to any extent that exceeds the maximum acceptable values (other than aesthetic guideline values) specified in the New Zealand Drinking Water Standards applicable at the time.

**Premises** The physical location to which a water supply is provided and includes:

- (a) a property or allotment which is held in a separate certificate of title or for which a separate certificate of title may be issued, and in respect of which a building consent has been or may be issued;
- (b) a building or part of a building which has been defined as an individual unit by a cross-lease, unit title or company lease;
- (c) an individual unit in a building where units are separately leased; or land held in public ownership (e.g. reserve) for a particular purpose.

*Advisory Note: Allotment means the same as defined in the Land Transfer Act 1952.*

**Property** A property or allotment which is held under separate certificate of title and a separate rating unit and showing on the Rating Information Database.

**Prescribed charges** Charges applicable at the time of connection may include:

- (a) Payment to the Council for the cost of the physical works required to provide the connection.
- (b) A development contribution determined in accordance with the Local Government Act



2002.

- (c) A financial contribution determined in accordance with the Resource Management Act 1991.
- (d) Bacteriological and chemical testing as per the Drinking Water Standards for New Zealand to ensure connection is safe.
- (e) Individual agreement charges.

**Public Notice**

A notice published in:

- (a) One or more daily newspapers circulated in the region or district of the Council;
- (b) One or more other newspapers that have at least an equivalent circulation in that region or district to the daily newspapers circulating in that region or district; or
- (c) Includes any other public notice that the Council thinks desirable in the circumstances.

**Restricted Flow Supply**

A type of water supply connection where a small flow is supplied through a flow control device, and storage is provided by the Customer to cater for demand fluctuations.

**Restrictor**

A flow control device installed within the connection to control the flow rate of water to a Customer's premises.

**Restricted Water Supply Area**

An area serviced by a Council owned reticulated water supply network outside on demand areas and defined in Schedule 3: Water Supply Area Maps Water is supplied through a flow control device and customers are required to provide onsite storage to cater for demand fluctuations.

**Service Pipe**

The section of water pipe between a water main and the point of supply.

**Storage Tank**

Any tank having a free water surface in which

water supplied by the Council is stored for use.

<b>Supply Pipe</b>	The section of pipe between the point of supply and the Customer's premises through which water is conveyed to the premises.
<b>Water Alert Level</b>	Classification system used for applying water conservation restrictions.
<b>Water Carrier</b>	Any individual drinking-water carrier or company registered with the Taumata Arowai as a recognised carrier of drinking- water.
<b>Water Supply Network</b>	<p>All those components of the water supply system between the point of abstraction from the natural environment and the point of supply. This includes but is not limited to:</p> <p style="margin-left: 40px;">(a) catchments, wells, infiltration galleries, intake structures, open raw water storage ponds/lakes/reservoirs, falling and rising mains, treatment plants, treated water reservoirs, trunk mains, service mains, rider mains, pump stations and pumps, valves, hydrants, scour lines, service pipes, boundary assemblies, meters, backflow prevention devices and tobies.</p>
<b>Water Unit</b>	The basis of measurement for water supply as determined by the Council. One unit is equal to one cubic metre.

## **8. Protection of Water Supply Network**

### **8.1. Water Supply Network**

#### **8.1.1. Access and connection to Network**

- (a) No person other than the Council and its authorised agents shall have access to any part of the water supply network, unless with prior approval.
- (b) Except as set out in Clause 8.1.2 (Fire Hydrants), no person shall make any connection or interfere with any part of the water supply network, unless with prior approval.

- (c) Where the water supply network becomes contaminated due to unauthorised access, the Council may recover cost of remediation of contamination.
- (d) Any person causing damage which occurs to a Council water supply network during unauthorised access shall be liable for the cost of repair and any other costs the Council incurs as a result of the incident.

### **8.1.2. Fire Hydrants**

- (a) No person may take water from a fire hydrant unless that person is:
  - i. taking the water for the purposes of firefighting and is a Fire and Emergency New Zealand personnel – as defined in the Fire and Emergency New Zealand Act 2017; or
  - ii. authorised to do so either by Council directly or through the granting of a permit in which case the taking of water is in accordance with any conditions attached to such approval.
- (b) Any person using a fire hydrant in breach of 8.1.2 (a) must immediately remove the standpipe when requested to do so by Council or their agent.
- (c) Any person using a fire hydrant pursuant to 8.1.2(a)(ii) is liable to Council for any damage or loss caused to the fire hydrant or the water supply network as a result of that use.
- (d) Without prejudice to other remedies available, the Council may seize and impound any equipment used by an offender to gain access to, or draw water from a fire hydrant, and assess and recover the value of water drawn without authorisation and any other associated costs.
- (e) Permit holders shall only use approved blue coloured metered standpipes and have two non-return valves to draw water from fire hydrants.

### **8.1.3. Working around Buried Services**

- (a) No person shall carry out any excavation without first reviewing the Council's records of the location of its buried services to establish whether or not Council services are located in the vicinity of the proposed works. The Council may charge a fee for the provision of this information and does not guarantee the accuracy or completeness of such information.

- (b) Where appropriate the Council may in its absolute discretion mark out to within  $\pm 0.5\text{m}$  on the ground the location of its services and nominate in writing any restrictions on the work it considers necessary to protect the integrity of the water supply network. The Council shall charge for this service.
- (c) All excavations within the road reserve is subject to the permit process of the appropriate road controlling authority.
- (d) The Council may require the independent supervision of works which may be in the vicinity of its buried services.
- (e) Every person excavating or working around the Council's buried water supply services shall take due care to ensure that the services are not damaged and that bedding and backfill is reinstated in accordance with the appropriate Council specification.
- (f) Any damage which occurs to the Council services shall be reported to the Council immediately. The person causing the damage shall be liable for the cost of repair and any other costs the Council incurs as a result of the damage.

*Advisory Note: All excavation and trenching work carried out within the road corridor must be carried out in accordance with the National Code of Practice for Utility Operators' Access to the Transport Corridor.*

## **8.2. Protection of Water Sources**

### **8.2.1. Catchment Classes**

Surface water and groundwater catchment areas from which untreated water is drawn for the purposes of water supply may be designated by Council as:

- (a) Controlled Catchment; or
- (b) Restricted Catchment; or
- (c) Open Catchment.

*Advisory Note: These catchments are also subject to National Environmental Standards for Sources of Human Drinking Water.*

### **8.2.2. Controlled Catchments**

- (a) No person shall enter Controlled Catchments except those specifically authorised or permitted in writing by the Council.

- (b) Every person on any Controlled Catchment Area or land held by the Council as a water reserve will, upon demand, produce any such permit for inspection.
- (c) The Council may, at any time, by notice in writing, revoke or suspend any such permit for such time as may be stated in such notice.
- (d) No permit issued by Council may be transferred. Every person shall, upon the request of an authorised officer of the Council, immediately leave the controlled catchment area or land held by the Council as a water reserve.
- (e) No person shall obstruct or hinder any duly appointed officer of the Council in the exercise of any powers vested in that officer under this Bylaw.

### **8.2.3. Restricted Catchments**

- (a) Certain activities are permitted within Restricted Catchment areas, such activities being limited to:
  - i. Tramping;
  - ii. Hunting;
  - iii. Trapping;
  - iv. Shooting; or
  - v. Fishing
- (b) No person may camp overnight in a Restricted Catchment area.
- (c) Every person shall, upon the request of an authorised officer of the Council, immediately leave the Restricted Catchment area.

### **8.2.4. Open Catchments**

In open catchment areas whether designated or not, there will generally be no restriction on activities other than the provisions of the Regional or the District Plan and the National Environmental Standards.

### **8.2.5. Spillages and Adverse Events**

- (a) In the event of a spillage, or any event which may compromise potable water or the water supply network, the person responsible for the event

shall advise the Council immediately. This requirement shall be in addition to those other notification procedures which are required for other authorities.

- (b) Where the owner or occupier of a premise allows or permits any item or items on the premises that may potentially contaminate or leach into the water supply and to accumulate on the premises contained within the catchment, the Council may request the owner or occupier to contain and remove the item or items using a Council approved method and location.
- (c) If the item(s) are not removed within the period specified, the Council or its authorised agents may remove the items and recover the costs from the Customer associated with containment, removal and disposal.

## **9. Conditions of supply**

### **9.1. Connection, Disconnection and other works**

- (a) No person shall, without Council's approval:
  - i. Connect to the water supply network;
  - ii. Disconnect from the water supply network;
  - iii. Carry out any other works on, or in relation to, the water supply network;
  - iv. Tamper with any, access point, valve on, or otherwise with the water supply network.
- (b) Any person wishing to connect to or disconnect from the water supply network, or to otherwise carry out works on such a network or change level of service or end use of water supplied or supply changes or increase supply, must make a written application for approval to Council on the prescribed form, and must provide with that application all information relating to the application as specified by Council.
- (c) Council may grant approval to such connection, disconnection or other works, as the case may be, and may impose conditions which must be complied with in the exercise of the approval.

The Council may require a Customer to enter into an individual Customer agreement and supply a Water Conservation and Demand Management Plan based on the Customer's water demand requirements.

- (d) Without limiting subclause 9.1(c), a condition imposed under that

subclause may require that the connection, disconnection or works comply with any relevant code of practice.

- (e) Council may refuse an application for approval to connect or disconnect to a network where:
- i. The applicant has not paid fees or charges associated with the connection (including development contributions) within 20 working days that have been required by Council to continue with installation, or has refused to provide such information relating to the application as has been specified by Council; or
  - ii. Council has a documented record of the applicant's non-compliance with this Bylaw or any previous water supply Bylaw, codes of practice, or approvals granted under such Bylaws or codes of practice; or
  - iii. in Council's reasonable opinion, there is insufficient capacity in the network to accommodate the connection; or
  - iv. in Council's reasonable opinion, the connection could compromise its ability to maintain levels of service in relation to the water supply including volume and/or pressure required for firefighting; or

*Advisory Note: Refer to [SNZ PAS 4509: 2008 New Zealand Fire Service Fire Fighting Water Supplies Code of Practice](#) for acceptable volume and pressure levels.*

- v. the connection is outside the area currently served by the water supply, regardless of its proximity to any specific component of the water supply; or
- vi. in Council's reasonable opinion, refusal is necessary to protect the water supply network, the health and safety of any person, or the environment.

## 9.2. Change of Use

- (a) An application shall be submitted to the Council for approval if a Customer seeks:
- i. a change in the level of service; or
  - ii. end use of water supplied to the premises; or
  - iii. a change in supply from ordinary to extraordinary (see clause 9.5)

or vice versa; or

- iv. a physical change of location or size.
- (b) Any application under this clause 9.2 shall be treated as a new application for the purposes of clause 9.1 of this Bylaw.

### 9.3. Point of Supply

#### 9.3.1. Ownership and Responsibility for Maintenance

- (a) The Council shall own and maintain the service pipe and fittings up to the point of supply. The Customer shall maintain the supply pipe and fittings beyond the point of supply.

*Advisory Note: The Council gives no guarantee regarding the serviceability of the valve located on the service pipe. Where there is no Customer stopcock, or where maintenance is required between the isolation valve and the Customer stopcock, the Customer may use the isolation valve to isolate the supply. However, the Council reserves the right to charge for maintenance of this valve if damaged by such Customer use.*

- (b) The Customer shall maintain the area in and around the point of supply by keeping it free of soil, growth, or other matter or obstruction which prevents, or is likely to prevent, convenient access to the point of supply.
- (c) Unless otherwise specified in this Bylaw, change of ownership (between Council and Customer), of water supply pipes and fittings occurs at the point of supply.
- (d) The Customer shall be solely responsible for maintaining the proper position (open or closed) of the Isolation Valve, commonly referred to as the Toby, and ensuring it is correctly set at all times. If any additional water use occurs as a result of the Isolation Valve position, the cost of such use shall also be the responsibility of the Customer.

*Advisory Note: The isolation valve is normally located at the front of the property under a blue or black plastic cover alongside the water meter.*

#### 9.3.2. Location

- (a) For each individual property there shall be only one point of supply, unless otherwise approved in writing by the Council. A point of supply shall be located in the position as shown in Schedule 1. Where fences, walls or other permanent structures make it difficult to locate it at the required position, the point of supply shall be located as close as possible



to the required position indicated in Schedule 1. The location of the point of supply in any position other than the required position shall require specific approval from Council. Any new point of supply shall be located outside the boundary of the premises in the position approved by the Council.

- (b) Existing points of supply may be located either inside or outside the property boundary. The Council may relocate the point of supply when deemed appropriate or on request from the Customer. The relocation of the point of supply, pipework and fittings from the new point of supply to the existing Customer supply pipe shall be the responsibility of the Council for six months from the time of relocation.

### **9.3.3. Multiple Ownership of Premises**

Where the premises are held in multiple ownership, the point of supply shall be as follows:

- (a) In respect of company ownership for a company share/block scheme (Body Corporate), the point of supply shall be located as shown in Schedule 1 or as or as close as possible where fences, walls, or other permanent structures make it difficult to locate it at the required position, unless otherwise approved. Other positions shall require specific approval from Council.
- (b) For Leasehold/Tenancy in Common Scheme (Cross Lease), Strata Title, Unit Title and any other form of multiple ownership, each Customer shall have an individual supply with the point of supply determined by agreement with the Council. In specific cases other arrangements may be acceptable, subject to the Council's approval.
- (c) Where a bulk meter feeds multiple units, a unit title must be nominated by the company or body corporate (whichever is relevant) to hold the bulk meter for payment purposes.

## **9.4. Access to and about the Point of Supply**

### **9.4.1. Rights of Access**

- (a) Where the point of supply is on private property the Customer shall allow the Council access to the point of supply between 7.30am and 6.00pm on any day for:
  - i. Meter reading without notice being given.
  - ii. Checking, testing and maintenance work, with notice being given

when possible.

- (b) For works required outside the above hours (such as for night-time leak detection), the Council shall provide notice to the Customer.
- (c) If, after giving reasonable notice, an authorised agent is prevented from accessing the point of supply at any of the above times and a return visit is required, a fee may be charged in accordance with the fees and charges. Where the point of supply is on private property the Customer shall allow the Council access to the point of supply between 7.30am and 6.00pm on any day.
- (d) In accordance with section 173 of the Local Government Act 2002, where there is an emergency, the Council shall enter the property without notice and the Customer shall allow the Council unobstructed access to, and about the point of supply at any hour.

## **9.5. Types of Water Supply**

### **9.5.1. General**

Water supplies shall be classified as either 'on demand' or 'restricted flow' and the use of water from the supply shall be either 'ordinary' or 'extraordinary'.

### **9.5.2. On Demand Supply**

- (a) All premises situated within the on demand water supply area shall be entitled to an ordinary supply of water subject to:
  - i. Any restrictions on water use made by the Council under clause 9.8.1 of this Bylaw;
  - ii. Payment of the appropriate charges in respect of supply to that premises;
  - iii. Any other charges or costs associated with subdivisional development; and
  - iv. Any other relevant conditions in section 8 of this bylaw.
- (b) Any premises which are located within the on- demand water supply area but do not connect to the public water supply may still be charged an availability charge in accordance with Council's fees and charges.
- (c) The Council shall be under no obligation to provide an extraordinary supply of water (see also the provisions of clause 9.8.1 of the Bylaw).

- (d) The Council shall charge customers for the provision of the on-demand supply by either:
  - i. A targeted rate based on rating unit; or
  - ii. The volume passing through a meter per cubic metre; or
  - iii. Both (i) and (ii) – These charges are as set by the Council.
- (e) For premises which use a fire protection system complying with SNZ PAS 4509: 2008, in order for that use to be classified as ordinary, the Customer shall comply with the conditions set under clause 9.8.

### **9.5.3. Restricted Flow Supply**

- (a) Restricted flow supply shall be available to premises in restricted supply areas under special conditions set by the Council. Customers receiving a restricted flow supply shall make provision for onsite water storage of a minimum volume of 22m<sup>3</sup> or equivalent of at least 48 hours of average water use where this is greater than 22m<sup>3</sup>.
- (b) This may include for the purposes of:
  - i. Rural supply within district; or
  - ii. Water demand management (including for drought, misuse and non-remedy of water leaks); or
- (c) The water supply shall be restricted so as to deliver 1.8m<sup>3</sup> per day or the agreed number of water units at a steady flow rate through a water meter.
- (d) The Council shall charge for the restricted supply by:
  - i. A targeted rate based on rating unit; or
  - ii. The volume passing through a meter per m<sup>3</sup>; or
  - iii. Both (i) and (ii) – These charges are as set by the Council.
- (e) All restricted supply storage tanks must include a suitable, testable backflow prevention device located at the boundary of the property.
- (f) Properties identified without flow restrictors in restricted supply areas may be given twelve weeks written notice to install onsite water storage

of a minimum volume of 22 cubic metres or the equivalent of at least 48 hours of average water use where this is greater than 22 cubic metres. After this period Council shall install the appropriately sized flow restrictor.

- i. Any property owner who receives written notice may make a written application within 10 working days of receiving such notice for an exemption.
  - ii. Matters which will be taken into account when assessing an application for exemption include (but are not limited to):
    - Location of the property;
    - The basis on which the exemption is claimed;
    - Any other matter which the Council deems relevant.
- (g) Owners are allowed to transfer water allocations subject to following conditions:
- i. The initial property retains a 1.8 cubic metre allocation;
  - ii. The transfer has to take place within the same water supply;
  - iii. The new property to which water allocation is transferred or sold has to be located at a place where the Council is able to supply the allocation without further upgrading or extension works;
  - iv. If upgrading or extension works are required then the Customer transferring the allocation has to pay up-front for the full cost of the upgrading or extension works; and
  - v. The Customer transferring the allocation has to pay for the connection cost to the new property and a transfer fee.
- (h) Council allows property owners to apply for disconnection from the restricted water supply. No refund either in part or whole of any development contribution will be made. Such an application must state the alternative water source the consumer will rely on. Council charges those property owners a disconnection fee to recover costs of effecting the disconnection. Should the owner wish to reconnect to a Council water scheme, reconnection fees will be charged.

*Advisory Note: The Council gives no guarantee regarding the serviceability of the valve located on the service pipe. Where there is no (Owner) stopcock or where maintenance is required between the isolation valve and the (Owner) stopcock, the (Owner) may use the isolation valve to*

*isolate the supply in an emergency. However, Council reserves the right to charge for maintenance of this valve if it is damaged by the (Owner) during use for this purpose.*

## **9.6. Meters and Flow Restrictors**

All water connections in Waikato District shall be metered.

### **9.6.1. Installation of meters**

- (a) Meters for on demand supplies, and restrictors for restricted flow supplies shall be supplied, installed and maintained by the Council, and shall remain the property of the Council.
- (b) The Council may fit a meter to any connection on any Premises at any time for the purposes of determining water consumption.
- (c) The Council may fit additional meters to any minor or ancillary dwelling located on any Premises, for the purposes of determining water consumption. This applies to premises with a connection to On Demand Supply and excludes Restricted Flow Supply, unless requested by the Property Owner.
- (d) Where a premises is supplied with an on demand water supply and is not metered, the Council reserves the right to fit a meter at the Customers cost and charge accordingly.

*Advisory Note: Clauses 9.6.1 (a) to (d) shall only apply to properties which have a connection to the water supply network.*

### **9.6.2. Location**

Meters and restrictors shall be located in a position where they are readily accessible for reading and maintenance, and if practicable immediately on the Council side of the point of supply.

### **9.6.3. Accuracy**

- (a) Meters shall be tested as and when required by the Council.
- (b) The flow restrictors shall be accurate to within  $\pm 10\%$  of their rated capacity.
- (c) Any Customer who disputes the accuracy of a meter or restrictor may apply to the Council for it to be tested provided that the testing is not requested within six months of any previous test. If the test shows the

meter is accurate, the Customer shall pay a fee in accordance with the Council's fees and charges. A copy of independent certification of the test result shall be made available to the Customer on request.

- (d) Restrictors shall be tested by measuring the quantity of water that flows through the restrictor within a period of not less than one hour, at the expected minimum operating pressure.

#### **9.6.4. Adjustment**

- (a) If a test is carried out and the meter is found to register a consumption which is different to the quantity of water which has actually passed through the meter, the Council shall make an adjustment in accordance with the results shown by such tests, backdated for a period determined by the Council but not exceeding 12 months, and the Customer shall pay a greater or lesser amount according to the adjustment.
- (b) Where a meter is under-reading by more than 20% or has stopped, the Council reserves the right to charge for the amount of water assessed as having been used over the past billing period, taking into account any seasonal variations in water demand, and charge the customer accordingly.
- (c) Where a meter is over-reading, the Council shall make appropriate adjustments to the Customer's account, based on a period of similar use and backdated to when it is agreed the over-reading is likely to have occurred.

#### **9.6.5. Estimating Consumption**

- (a) Where a meter is damaged, ceases to register, has been removed or where the seal or dial of the meter is broken, or the meter has otherwise been interfered with, the Council shall estimate the consumption for the period since the previous reading of such meter, (based on the average of the previous four billing periods charged to the Customer) and the Customer shall be liable for the amount estimated.
- (b) If the average of the previous four billing periods would be an unreasonable estimate of the consumption (due to seasonal or other causes), the Council may consider other evidence for the purpose of arriving at a reasonable estimate, and the Customer shall pay according to such an estimate.
- (c) Where the Customer is a non-profit organisation, and the meter indicates a significant increase in consumption, and it is established that the increase is caused by a previously unknown leak, the Council may

estimate consumption as provided for in clause 9.6.5 (a) providing that the Customer repairs the leak as soon as is practicable.

- (d) Where an unauthorised connection has been made to the Council's water supply network, the Council will estimate the consumption for the period from when the connection was made, using the uniform charge for water on a pro rata basis. Where a meter has been installed without approval, and such meter complies with Council's standards for meters and installation, the full consumption registered on the meter shall be payable by the current occupier of the premises. Payment of the estimated charge does not preclude Council from taking any other enforcement action available to it.

#### **9.6.6. Incorrect Accounts**

- (a) Where a situation occurs, other than as described in clause 9.6.5, and the recorded consumption does not accurately represent the actual consumption on a property, the account shall be adjusted using the best information available to the Council. Such situations include, but are not limited to, misreading of the meter, errors in data processing, meters assigned to the wrong account, and unauthorised water supplies.
- (b) Where an adjustment is required in favour of the Council or the Customer, the adjustment shall not be backdated more than 12 months from the date the error was detected.

#### **9.6.7. Leaks**

- (a) It is the Customer's responsibility to detect and fix all leaks from taps and pipes, stop overflows from cisterns, hot water cylinder exhausts or stock troughs. If a leak is visible from fixtures and is not repaired, no leak relief remission will be available.
- (b) Relief may be available, at Council's discretion for leaks which are undetected.
- (c) Any Customer wishing to apply for relief must make such application in writing in accordance with Council's Water Leak Remission Policy.

### **9.7. Levels of Service and Continuity of Supply**

- (a) Although Council shall make all endeavors to provide water in accordance with the level of service set out in Schedule 2, due to practical and physical limitations, the Council cannot guarantee an uninterrupted or constant supply of water in all circumstances, or the continuous maintenance of any particular water pressure.

- (b) Where planned permanent or temporary works will affect an existing supply, the Council shall inform or give notice to all Customers who, in the opinion of Council, are likely to be substantially affected.
- (c) If a Customer has a particular requirement for an uninterrupted level of service (flow, pressure, or quality), it shall be the responsibility of that Customer to provide any storage, back-up facilities, or equipment necessary to provide that level of service.

## **9.8. Demand Management**

- (a) Where required by rules in a District Plan, owners must maintain devices that have been installed for the purposes of water demand management and in accordance with an associated integrated catchment management plan.

### **9.8.1. Water Alert and Emergency Restrictions**

- (a) In circumstances where natural hazards (such as floods, droughts or earthquakes) or accidents result in disruptions to the supply of water, Council may declare a water alert level or an emergency for the purposes of the supply of water and shall be exempt from the levels of service requirements.
- (b) During a water alert and/or emergency the Council may restrict or prohibit the use of water for any specified purpose or period, and for any or all of its Customers. Such restrictions shall be advised by public notice. The Customer shall comply with any restrictions imposed by Council, until such time as Council advises the restrictions are no longer in place.
- (c) The Council may, after serving notice and taking all practicable steps to contact a Customer, restrict and or meter the supply to reduce unnecessary and unauthorised water use and wastage where it deems necessary.

### **9.8.2. Maintenance and Repair**

- (a) In circumstances where a scheduled maintenance shutdown of the supply is required, Council shall make all practicable attempts to notify Customers prior to any work commencing. Where Council is unable to notify the Customer, or immediate action is required, the Council may restrict the supply without notice.
- (b) Where a Customer has assets restricting the maintenance of a Council water supply network, the Council shall not be responsible for damage



caused to the asset in order to maintain the Council water supply network.

- (c) If Council must carry out repairs or maintenance to privately owned supply pipes and/or water assets, the costs of such repairs or maintenance may be recovered from the Customer responsible for the pipes and/or assets.

## 9.9. Liability

The Council shall not be liable for any loss, damage or inconvenience incurred by a Customer (or any person using the supply) because of a reduced level of service of, or interruptions to the water supply.

## 9.10. Fire Protection Connection

### 9.10.1. Connection Application

An application to install a connection for fire protection purposes must be made, in writing, to the Council. Council may impose any conditions it determines are appropriate.

### 9.10.2. Design of Fire Protection Systems

As part of the application to install a connection for fire protection purposes, the Customer shall demonstrate to the Council that the available supply is adequate for the intended purpose. It shall also be the Customers responsibility to monitor the supply to ensure it continues to be adequate for the intended purpose.

*Advisory Note: For further information on fire safety water sprinkler or storage requirements refer to the [SNZ PAS 4509: 2008 New Zealand Fire Service Fire Fighting Water Supplies Code of Practice](#). Customers may also wish to consult with the New Zealand Fire Service Fire and Emergency New Zealand about suitable measures to provide firefighting protection for their properties.*

### 9.10.3. Fire Protection Connection Metering

- (a) Where a fire connection has been installed (or located) so that it is likely or possible that water may be drawn from it by any person for purposes other than firefighting, the Council may charge for the usage.
- (b) Where the supply of water to any premises is metered, fire hose reels shall be connected only to the metered supply, not to the fire protection system. The water supply to fire hose reels shall comply with the requirements of NZS 4503:2005 Hand operated fire-fighting equipment.

- (c) Water used for the purpose of extinguishing fires shall be supplied free of charge. Where the fire protection connection is metered, and water has been used for firefighting purposes, the Council shall estimate the quantity of water used, and credit to the Customer's account an amount based on such an estimate.
- (d) Owners intending to test fire protection systems in a manner that requires a draw-off of water must obtain the approval of the Council beforehand. Water used for routine flushing and flow testing does not constitute waste, but the quantity of water used may be assessed and charged for by the Council.

## 9.11. Backflow Prevention

### 9.11.1. Customer Responsibility

It is the Customer's responsibility to take all necessary measures on the Customer's side of the point of supply to prevent water which has been drawn from the Council's water supply from returning to that supply. All necessary measures shall include:

- (a) Backflow prevention either by providing an adequate air gap, or the use of an appropriate backflow prevention device; and/or
- (b) The provision for the exclusion of any cross-connection between the Council water supply and:
  - i. Any other water supply (potable or non-potable)
  - ii. Any other water source
  - iii. Any storage tank
  - iv. Any other pipe, fixture or equipment containing chemicals, liquids, gases, or other non-potable substances.

*Advisory Note: Fire protection systems that include appropriate backflow prevention measures would generally not require additional backflow prevention, except in cases where the system is supplied by a non-potable source or a storage tank or fire pump that operates at a pressure in excess of the Council's normal minimum operating pressure.*

*Advisory Note: The type of back flow prevention device to be used is dependent on the risk to the water supply posed by the Customer.*

### **9.11.2. Unmanaged Risk**

Where a Customer is unable to demonstrate that the risk of backflow is adequately managed or fails to take all necessary measures as required in clause 9.11.1 of the Bylaw, the Council may undertake the required works and fit a backflow prevention device on the Council side of the point of supply. In accordance with section 186 of the Local Government Act 2002, Council may recover such costs as a debt from the Customer.

Council will undertake a periodic surveying of existing connections to determine integrity and suitability of the backflow prevention device installed from each point of supply.

*Advisory Note: Testable backflow prevention devices, require annual testing by a qualified or Council approved contractor. A test report shall be submitted to the Council for the Customer owned devices.*

## **9.12. Council Equipment and Inspection**

### **9.12.1. Care of Water Supply Network**

The Customer of the premises shall not damage or tamper with any part of the water supply network, including but not limited to pipe-work, valves, meters, restrictors, chambers, and backflow prevention devices. Should any damage occur which requires repairs, the Council reserves the right to recover the cost of such damage and/or repairs as a debt from the Customer.

### **9.12.2. Inspection**

In accordance with section 182 of the Local Government Act 2002, the Customer shall allow the Council or its agents, with or without equipment, access to any area of the premises for the purposes of determining compliance with this Bylaw.

## **9.13. Plumbing System**

### **9.13.1.**

The Customer's plumbing system shall be designed, installed and maintained, both in its component parts and its entirety, to ensure it complies with the Regional Infrastructure Specifications (RITS) or its amendments, Building Act 2004 and the New Zealand Building Code and is compatible with the water supply service as listed in Schedule 2.

### **9.13.2.**

Quick-closing valves, pumps, hydraulically driven equipment or any other equipment which may cause pressure surges or fluctuations to be transmitted within the water supply network or compromise the ability of the Council to maintain its stated levels of service, shall not be used on any piping beyond the point of supply. In special circumstances such equipment may be approved by the Council at its discretion. A gate valve shall not be used to control the water supply flow to the premises.

#### **9.14. Prevention of Water Loss and Waste**

##### **9.14.1.**

The Customer shall not allow water to run to waste from any pipe, tap, or other fitting, nor allow the condition of the plumbing within the premises to deteriorate to the point where leakage or wastage occurs.

##### **9.14.2.**

Water is provided by the Council for consumption purposes only. The Customer shall not use water or water pressure directly from the supply for driving lifts, machinery, educators, generators, or any other similar device, unless specifically approved by the Council.

##### **9.14.3.**

The Customer shall not use water for a single pass cooling system or to dilute trade waste prior to disposal, unless specifically approved by the Council.

##### **9.14.4.**

Where a Customer ignores advice from the Council to repair an on-going leak, the Council may after serving notice, repair the leak and charge the Customer all associated cost as provided in the Local Government Act 2002.

*Advisory Note: The Waikato District Plan sets out water saving measures required for water supply connections.*

#### **9.15. Payment**

##### **9.15.1.**

The Customer shall be liable to pay for the supply of water and related services in accordance with the Council's rates, fees and charges prevailing at the time.

##### **9.15.2.**

The Council may recover unpaid water rates in respect of the supply of water as prescribed in the Local Government (Rating) Act 2002 from the owner of a premises, the occupier of a premises, or both.

## **9.16. Transfer of Rights and Responsibilities**

### **9.16.1.**

The Customer shall not transfer to any other party the rights and responsibilities set out in this Bylaw.

## **9.17. Change of Ownership**

### **9.17.1.**

In the event of a premises changing ownership the new owner will be recorded as the customer at those premises from the date of notification. Where the premises are metered, the outgoing Customer shall give the Council ten working days' notice to arrange a final meter reading.

### **9.17.2.**

The Council reserves the right to reassess the conditions of supply when a change of ownership occurs.

### **9.17.3.**

The owner of the premises at the time of the consumption is responsible for any water charges.

## **9.18. Disconnection at the Customer's Request**

The Customer shall give 10 working days' notice in writing to the Council of a requirement for disconnection of the supply. Disconnection shall be at the Customer's cost.

## **10. Breaches**

### **10.1. Breaches of conditions of supply**

#### **10.1.1**

The following are deemed to be breaches of the conditions to supply water:

- (a) An incorrect application for supply which fundamentally affects the conditions of supply;

- (b) Failure to meet any obligations placed on the Customer under all Codes and Standards specified in this Bylaw;
- (c) An act or omission including but not limited to any of the following:
  - i. Any tampering or interference with Council equipment/assets, either directly or indirectly;
  - ii. Failure to pay the appropriate charges by the due date;
  - iii. Frustration of the Council's ability to adequately and effectively carry out its obligations;
  - iv. Failure to repair a leak, or in any way willfully allowing water to run to waste, or to be misused;
  - v. The fitting of quick-closing valves, pumps, or any other equipment which may cause pressure surges or fluctuations to be transmitted within the water supply network, or compromise the ability of the Council to maintain its stated levels of service (subject to clause 9.5 of this Bylaw);
  - vi. Failure to prevent backflow;
  - vii. Failure to maintain or inspect backflow;
  - viii. Using water or water pressure directly from supply for driving lifts, machinery, educators, generators, or any other similar device, unless specifically approved by the Council;
  - ix. Using water for a single pass cooling or heating system, or to dilute trade waste prior to disposal, unless specifically approved;
  - x. Extending by hose or any other pipe a private water supply beyond that Customer's property;
  - xi. Providing water drawn from the Council supply to any other party without approval of the Council;
  - xii. Unauthorised removal of flow restrictors.
- (d) Every person commits a breach of this Bylaw and commits an offence who:
  - i. Does, permits or allows anything to be done, which is contrary to

this Bylaw;

- ii. Fails to do or perform any act, or thing, that they are required to do by this Bylaw, within the time and in the manner required by the Bylaw, or any part of it;
- iii. Commits any breach of the terms and conditions of this Bylaw;
- iv. Does anything prohibited by this Bylaw;
- v. Fails to comply with any notice given under this Bylaw or any part of it or any condition that is part of any notice granted by the Council;
- vi. Where required, fails to obtain written approval or having obtained written approval fails to abide by the conditions (if any);
- vii. Obstructs or hinders any authorised officer in the performance of any duty or in exercising any power conferred by this Bylaw;
- viii. Tampers or interferes with any part of the Council owned water supply network without a permit;
- ix. Withdraws water from a fire hydrant without authorisation from the Council for any other purpose than fire protection;
- x. Fails to comply with water use restriction or prohibitions introduced by the Council for any specific purpose;
- xi. Fails to meet any obligations placed on the Customer through any permit conditions;
- xii. Fails to meet any obligations placed on the Customer through an individual Customer agreement;
- xiii. Other than the Council or its authorised agents, who accesses the water supply network without a valid permit breaches this Bylaw.

### **10.1.2**

In the event of a breach of any provision of this Bylaw, the Council shall serve notice on the Customer advising the nature of the breach, the steps to be taken, and required timeframe to remedy the breach to the satisfaction of the Council beyond timeframe indicated. If the Customer persists with the breach the Council reserves the right to:

- (a) Reduce the flow rate of water to the Customer without notice.

Reinstatement of full supply shall be re-established only after the Customer completes payment of the appropriate fee and remedy of the breach to the satisfaction of the Council.

- (b) Install a water meter. The Customer will also be charged for the ongoing supply of water as per Council's fees and charges for water supply as determined by Council from time to time.
- (c) For extraordinary supply – disconnect the water supply for all purposes other than domestic water use.
- (d) If the breach is such that the Council is required to disconnect the supply for health or safety reasons, disconnection may occur immediately and without further notice to the Customer.

## **10.2. Interference with equipment**

Any tampering or interfering with Council equipment, either directly or indirectly, shall constitute a breach of this Bylaw.

## **11. Offences and Penalties**

A person who fails to comply with the requirements of this Bylaw commits a breach of this Bylaw and is liable to a penalty under the Local Government Act 2002.

## **12. Schedules**

The following schedules can be amended through a Council resolution.

**Schedule 1:** Examples showing Single/Manifold Connection

**Schedule 2:** Table 1 Compatibility Features

**Schedule 3:** Water Supply Area Maps

## **13. General**

Any notice, order or other document which is required by this Bylaw to be served or given or sent to any person shall be deemed to have been duly served given or sent if delivered to such person or left at his or her residence or workplace or posted to such person at his or her last known address.

Any resolution of the Council may be amended, rescinded or reinstated by a further resolution of the Council.



This Bylaw was made pursuant to a resolution passed by the Waikato District Council on 18 December 2023.

**THE COMMON SEAL of WAIKATO DISTRICT COUNCIL** was hereto affixed in the presence of:

  
 \_\_\_\_\_
   
 Mayor



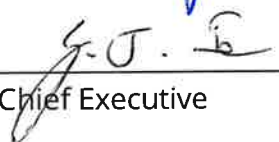

  
 \_\_\_\_\_
   
 Chief Executive

Activity	Key Date	Council resolution
Bylaw made	18 December 2023	P&RHE2311/04
Bylaw reviewed		
Next review due date		

**Schedule 1: Examples showing Single/Manifold Connection**

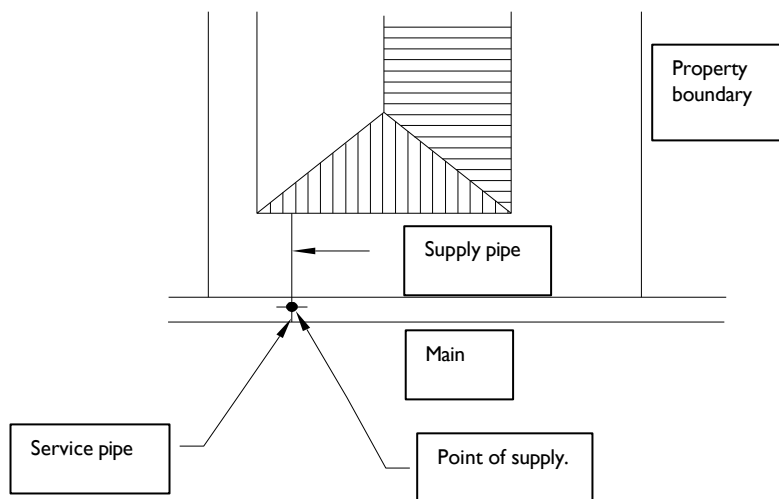
**Example 1: With Street Frontage**



**Figure 1: Point of supply outside property boundary**

**Example 2: Rear lots on right of way (up to 2 customers)**

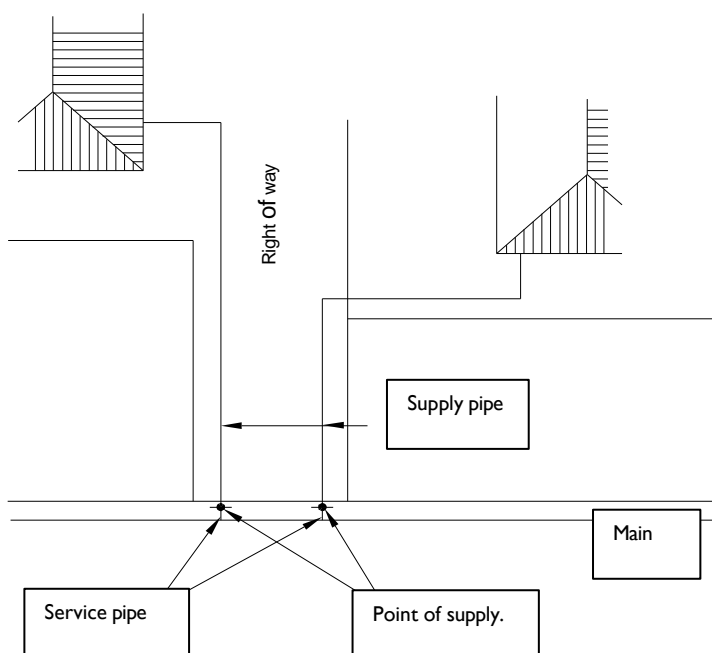

**Figure 2: Point of supply outside property boundary**

**Example 3:** Rear lots on right of way (3 or more customers)

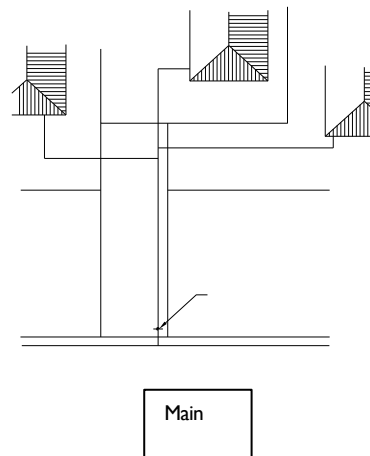
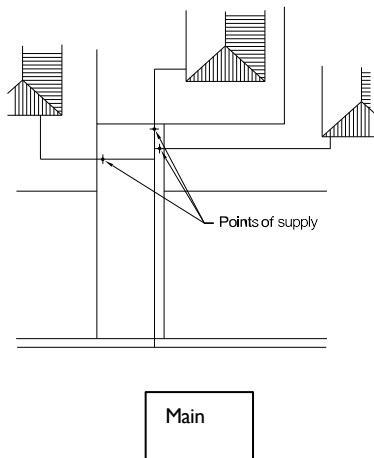

**Figure 3: Point of supply outside property boundary**

**Figure 4: Common point of supply**

**Example 4:** Industrial, commercial, domestic fire and service connections including schools)

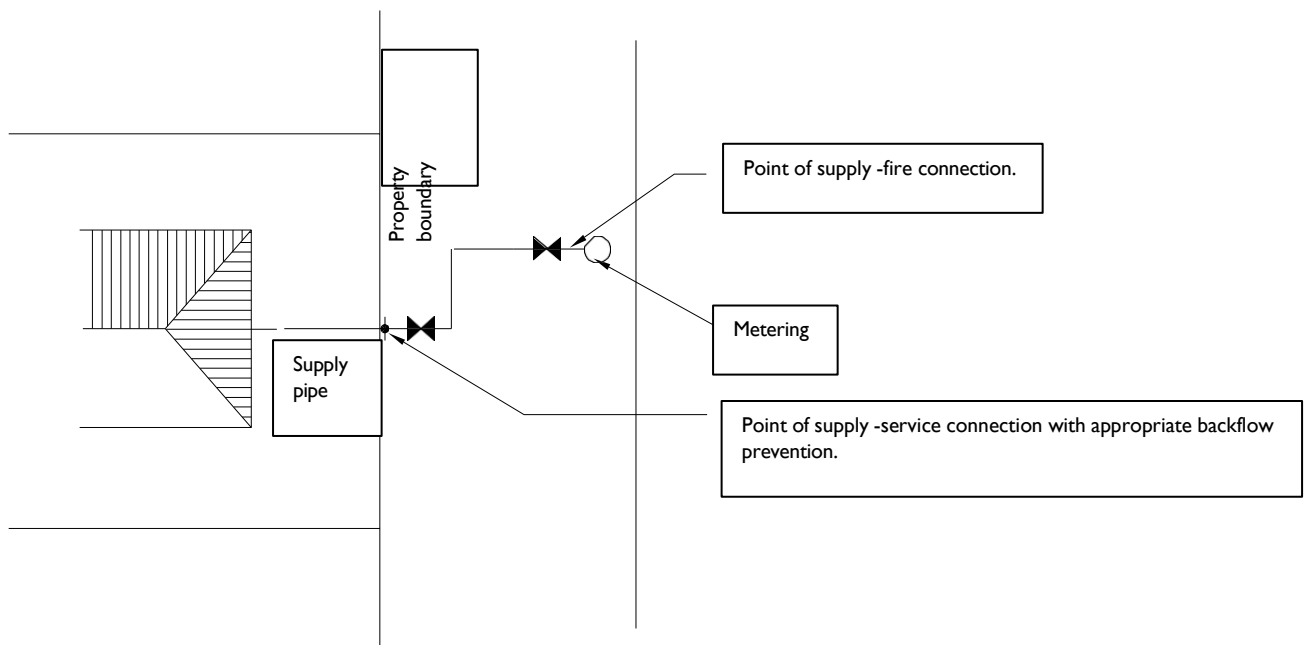

**Figure 5: Combined fire and service connection**

**Advisory Note:** Refer to SNZ PAS 4509: 2008 New Zealand Fire Service Fire Fighting Water Supplies Code of Practice for guidance on appropriate fire supply connection location.

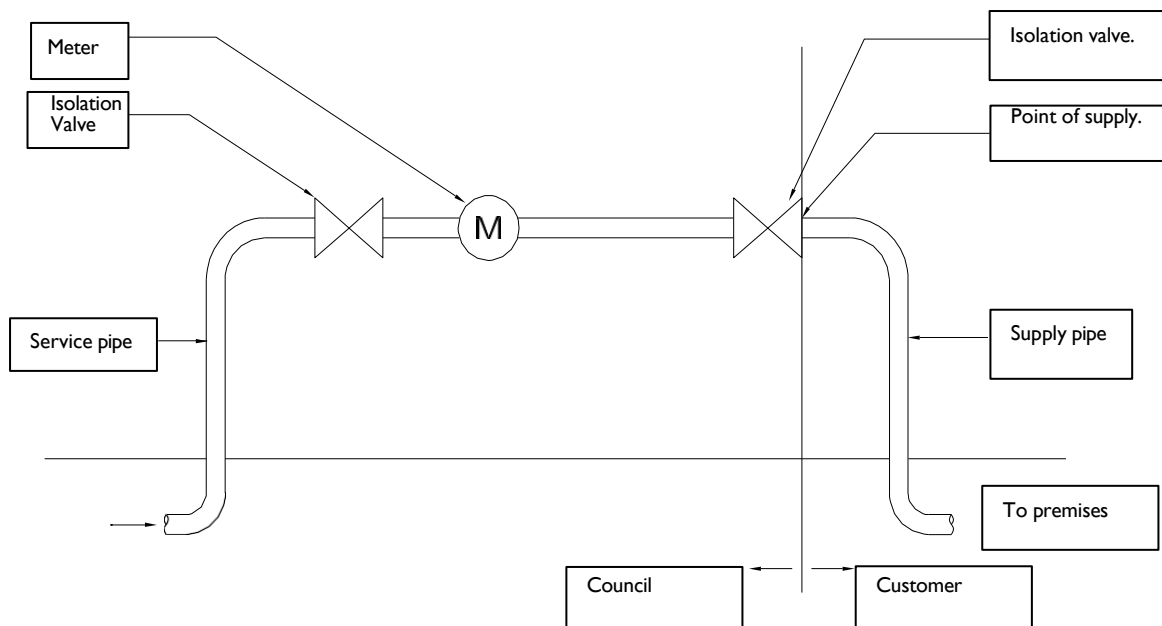
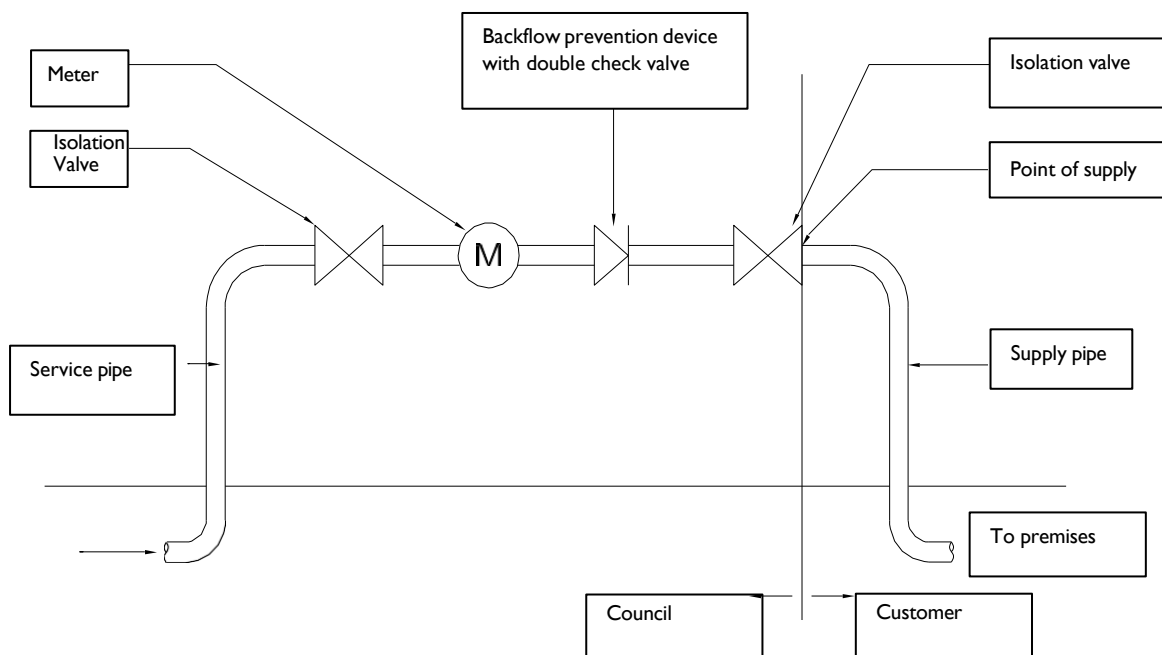

Figure 6: Domestic metered supply

**Note:**

1. Point of supply is tail piece of boundary box, meter, or isolation valve regardless of property boundary.
2. The New Zealand Building Code may require the Customer to install additional backflow prevention devices within the site, which will remain the responsibility of the Customer.



**Figure 7: Metered supply with backflow prevention device owned by Council**

**Note:**

1. Point of supply is tail piece of boundary box, meter, or isolation valve regardless of property boundary.
2. The New Zealand Building Code may require the Customer to install additional backflow prevention devices within the site, which will remain the responsibility of the Customer.

## Schedule 2: Table 1 Compatibility Features

Specific features of the Council supply which need to be taken into account are contained in Table 1 below.

**Table 1:** Compatibility features

Feature	Value
Maximum operating pressure	100 metres head (1, 000 kPa)
Minimum operating pressure*	20 metres head (100 kPa)
Normal operating pressure	30 – 40metres head (200 - 300 kPa)
Free available chlorine	Up to 1.5 g/m <sup>3</sup>
Min operating pressure (for rural supplies)	10 meters head (100 kPa)

*\*Minimum pressure refers to on demand water supplies only*

## Schedule 3: Water Supply Area Maps

### **Pokeno**

<https://waikatodc.spatial.t1cloud.com/spatial/intramaps/?project=Public&module=Utilities&configId=e6b2fca7-5d63-4aed-b49c-c32dc8cb1002&startToken=6ee29987-d21a-4765-9f52-ed1f51e620e2>

### **Raglan, Te Akau, Western Districts & Onewhero**

<https://waikatodc.spatial.t1cloud.com/spatial/intramaps/?project=Public&module=Utilities&configId=e6b2fca7-5d63-4aed-b49c-c32dc8cb1002&startToken=0f63eb87-3a54-4580-8bba-8dbfe04db53d>

### **Ngaaruawaahia, Taupiri & Hopuhopu**

<https://waikatodc.spatial.t1cloud.com/spatial/intramaps/?project=Public&module=Utilities&configId=e6b2fca7-5d63-4aed-b49c-c32dc8cb1002&startToken=e78963c8-bdcb-4b3a-8a5a-e62e601ef967>

### **Huntly**

<https://waikatodc.spatial.t1cloud.com/spatial/intramaps/?project=Public&module=Utilities&configId=e6b2fca7-5d63-4aed-b49c-c32dc8cb1002&startToken=e19282d9-22b6-4a6d-939a-b02c85e2539d>

### **Southern Districts**

<https://waikatodc.spatial.t1cloud.com/spatial/intramaps/?project=Public&module=Utilities&configId=e6b2fca7-5d63-4aed-b49c-c32dc8cb1002&startToken=639f77f4-2657-42a1-8502-8ab72db49071>

### **Te Kauwhata and Surrounds**

<https://waikatodc.spatial.t1cloud.com/spatial/intramaps/?project=Public&module=Utilities&configId=e6b2fca7-5d63-4aed-b49c-c32dc8cb1002&startToken=324a9778-4b44-4938-891e-97454262fef2>

### **Tuakau**

<https://waikatodc.spatial.t1cloud.com/spatial/intramaps/?project=Public&module=Utilities&configId=e6b2fca7-5d63-4aed-b49c-c32dc8cb1002&startToken=3fec4d6-c5aa-468e-a672-9cc0aeb499d4>

### **Port Waikato**

<https://waikatodc.spatial.t1cloud.com/spatial/intramaps/?project=Public&module=Utilities&configId=e6b2fca7-5d63-4aed-b49c-c32dc8cb1002&startToken=cfc4af0a-72da-443b-8885-4450b5bdee3d>