

Agenda for a meeting of the Ngaruawahia Community Board to be held in the Committee Rooms 1 & 2, District Office, 15 Galileo Street, Ngaruawahia on **TUESDAY, 28 MARCH 2023** commencing at **6.00pm**.

Information and recommendations are included in the reports to assist the Board in the decision making process and may not constitute Council's decision or policy until considered by the Board.

1. APOLOGIES AND LEAVE OF ABSENCE

2. CONFIRMATION OF STATUS OF AGENDA

3. DISCLOSURES OF INTEREST

The register of interests is no longer included on agendas, however members still have a duty to disclose any interests under this item.

4. CONFIRMATION OF MINUTES

Meeting held on Wednesday, 22nd February 2023. 3

5. PUBLIC FORUM

6. REPORTS

- | | | |
|-----|--|----------------|
| 6.1 | Discretionary Fund Report - monthly | 12 |
| | • <i>Application for Funding – Ngaruawahia Community House</i> | |
| 6.2 | Ngaruawahia Works and Issues Report | 16 |
| 6.3 | Proposed Road Name Application - SUB0013/21 – 24 Jackson Street | 20 |
| 6.4 | Infrastructure Acceleration Fund – Festival Way/Galbraith Street | 30 |
| 6.5 | Chairperson's Report | <i>Verbal</i> |
| 6.6 | Councillors' Report | <i>Written</i> |
| 6.7 | Community Board Members' Report | <i>Verbal</i> |

GJ Ion
CHIEF EXECUTIVE

To	Ngaruawahia Community Board
Report title	Confirmation of Minutes
Date:	Friday, 17 March 2023
Report Author:	Elizabeth Saunders, Democracy Advisor
Authorised by:	Gaylene Kanawa, Democracy Manager

1. Purpose of the report

Te Take moo te puurongo

To confirm the minutes for the meeting of the Ngaruawahia Community Board held on Wednesday, 22 February 2023.

2. Staff recommendations

Tuutohu-aa-kaimahi

THAT the minutes for the meeting of the Ngaruawahia Community Board held on Wednesday, 22 February 2023 be confirmed as a true and correct record.

3. Attachments

Ngaa taapirihanga

Attachment 1 – NCB Meeting Minutes – 22 February 2023.

MINUTES for the meeting of the Ngaruawahia Community Board held in the Committee Rooms 1 & 2, District Office, 15 Galileo Street, Ngaruawahia on **WEDNESDAY, 22 FEBRUARY 2023** commencing at **6.00pm**

Present:

Ms K Morgan (Chairperson)
 Mr J Ayers
 Ms D Firth
 Ms K Hooker
 Cr E Patterson
 Cr T Turner
 Mr G Wiechern

Attending:

Her Worship the Mayor, Mrs JA Church – *until 7.14pm*
 Ms P Giles (Waikato District Alliance – Roading Inspector)
 Mr A Nichols (Waikato District Alliance)
 Mrs L Van Den Bemd (Community Led Development Advisor)
 Ms K Rhind (Senior Community Engagement Advisor)
 Ms E Wilson (Contracts & Compliance Co-ordinator)
 Ms E Saunders (Democracy Advisor)

APOLOGIES AND LEAVE OF ABSENCE

Resolved: (Ms Morgan/Ms Firth)

THAT the Ngaruawahia Community Board accepts the:

- a. **apologies for non-attendance from Ms V Rice and Ms Ngahina Armstrong-Nield (Iwi & Community Partnerships Advisor); and**
- b. **apology from Mr K Abbot (Executive Manager – Partnerships & Innovation) for absence on Council business.**

CARRIED

NCB2302/01

CONFIRMATION OF STATUS OF AGENDA ITEMS

Resolved: (Mr Wiechern/Mr Ayers)

THAT:

- a. the agenda for a meeting of the Ngaruawahia Community Board held on Wednesday, 22 February 2023 be confirmed and all items therein be considered in open meeting; and
- b. all reports be received.

CARRIED

NCB2302/02

DISCLOSURES OF INTEREST

There were no disclosures of interest.

CONFIRMATION OF MINUTES

Resolved: (Cr Patterson/Ms Firth)

THAT the minutes for a meeting for the Ngaruawahia Community Board held on Tuesday, 6 December 2022 be confirmed as a true and correct record.

CARRIED

NCB2302/03

PUBLIC FORUM

Agenda Item 5

The following items were discussed at the public forum:

Introductions:

- Ms P Giles and Mr A Nichols introduced themselves to the Board and outlined what they do in their roles with Waikato District Alliance Rooding Team.
- Her Worship the Mayor, Mrs JA Church introduced herself to the Board and Ms K Morgan acknowledged the efforts of the Civil Defence Team during Cyclone Gabrielle.
- Ms E Wilson, Mrs L Van Den Bemd and Ms K Rhind individually introduced themselves to the Board and outlined their various roles within Council.

REPORTS

Discretionary Fund Report Agenda Item 6.1

The report was received [NCB2302/02 refers] and the following discussion was held:

- There were some items in the report that needed further clarification and removal. The Democracy Advisor would follow this up with the Finance Team.

ACTION: Democracy Advisor to follow up the Commitment of \$2,000 for the Dog Agility Park to confirm it had been paid.

ACTION: Democracy Advisor to follow up with Finance for the Graham Dingle Foundation \$2,000 commitment and confirm it had already been paid, therefore was a double up.

Discretionary Fund Representative – Ngaruawahia Community Board Agenda Item 6.2

The report was received [NCB2302/02 refers] and the following discussion was held:

- It was confirmed that there could be a support person appointed to assist in the funding space for Ngaruawahia Community Board.
- Training would be provided for the funding representative by the end of March 2023.
- Accountability reports from successful funding applicants would also be required moving forward. It is good for the Board to have a report provided to show how the funds were used.

ACTION: Community Led Development Team to work with Democracy Team to schedule a training session for Discretionary Funding Representatives.

ACTION: Community Led Development Team to follow up the accountability reports received for all Community Boards/Committees for inclusion on the April agendas.

Resolved: (Cr Patterson/Mr Ayers)

THAT the Ngaruawahia Community Board Chairperson be appointed to be the funding representative for the 2022-2025 triennium along with Ms K Hooker to support the funding representative as a secondary.

CARRIED

NCB2302/04

Community Board Executive Committee – Representative Vote
Agenda Item 6.3

The report was received [NCB2302/02 refers] and no further discussion was held.

Resolved: (Mr Wiechern/Cr Turner)

THAT the Ngaruawahia Community Board votes for Phill Thomass to represent Zone 2 for the Community Board Executive Council.

CARRIED

NCB2302/05

Ngaruawahia Works & Issues Report
Agenda Item 6.4

The report was received [NCB2302/02 refers] and the following discussion was held.

- Construction at Ngaruawahia High School was ready for roading and Mr K Abbot was aware of this.
- It was noted that more street names could be added to the Ngaruawahia Roding Naming List and it was decided that this would be workshopped at a later time during the year in conjunction with the community.
- It was also noted that it was good to keep replenishing the list as time goes on to ensure consistency with the development process.

ACTION: A workshop to be organised with the Board and Roding Team for later on in 2023 to look at more street names for the Ngaruawahia approved list.

Chairpersons Report
Agenda Item 6.5

The chairperson provided a verbal report on the following items:

- So many blessings and positivity throughout Cyclone Gabrielle.
- Meetings had been attended and the Christmas break up with Taupiri Community Board was fun and great to attend.
- Future Local Government reform hui was attended through Zoom.
- Traffic Bylaw and Public Places: More proactiveness from the Board was required to ensure this bylaw is well responded to.

- The chairperson attended daily Civil Defence updates and wanted to acknowledge the teams in the Emergency Operating Centre. Feedback was provided around communications and more clarity required moving forward (i.e - access for staff to the Community Board Facebook page for more direct messaging straight to the community).
- Annual Plan Hui was attended – The Chairperson was getting an understanding of the process and where Ngaruawahia Community Board fit and how best to ensure projects are being completed.
- There was a lot going on for the Chairperson but is enjoying the mahi that was happening.
- Some work with Sam Toka had been done around Karakia and Te Ao Maori Kaupapa.
- Printed Agendas were appreciated and the Democracy Advisor would continue to print and leave at head office for pick up.

Councillor's Reports

Agenda Item 6.6

Verbal reports were received on the following items:

- Structure Plan for Ngaruawahia/Taupiri/Hopuhopu was ongoing and workshops were progressing.
- First Sustainability & Wellbeing committee meeting occurred this morning which was great to attend with some good discussion around economic development.
- Both Councillors had been extremely busy with multiple meetings and workshops attended over the last couple of weeks.
- Papakainga Housing work was being undertaken by Cr Turner, particularly around templates and the best way forward.
- There were two more meetings this week - Proposed District Plan and Council.
- Motorbikes – these were becoming a very frustrating issue for our community.
- First Whatawhata Community Hui two weeks ago took place and it was great to attend and get involved with the issues and concerns in that community.
- An acknowledgement was made to the Chairperson for the great meeting structure.
- Mana Whenua forums: Cr Turner advised she is making traction in this space and working with the Iwi & Community Partnerships Team. They were working on strategy and processes and getting a representative for each marae to make it consistent and open for all staff and marae.
- Tainui Games were attended by Cr Turner along with staff – it was a great engagement opportunity and a valuable insight into the communities thoughts around Council and engagement.

- Next step for Cr Turner with Mana Whenua Forums was to connect marae with the relevant council staff and to leave the operations side of things with staff to progress and complete.
- Both Councillors were trying to connect with all Community Committees to get a face into these areas – it was about reaching out to committees along with Community Boards.
- Cr Turner would continue attending Poukai to hear maori constituents voices. There was a discussion around safety for marae with the significant weather events and future planning around civil defence capabilities.
- A discussion around Turangawaewae Poukai and attending as a whole Board to make connections. This might not happen in 2023 but keep it on the schedule. A brief history of Poukai and their importance was provided to the Board by Cr Turner.

Community Board Members' Reports

Agenda Item 6.7

Verbal reports were received on the following items:

- A Zoom hui was attended around the Ngaruawahia/Taupiri/Hopuhopu Structure Plan - looking at starting community hui with each town from the 6-8 March with community members.
- Community Blueprint to be looked at during the next Ngaruawahia Community Board workshop.
- Community Safety – Police to be invited to either the next workshop or Community Board meeting.
- Waipa Tavern: Cr Patterson had an informal catch up with owner of the Tavern and a new timeline for removal has been decided by 1 April 2023. The owner did not reschedule from December so contractors are not available until April now. Cr Patterson would touch base with Contractors tomorrow to confirm timeline of removal of burnt structure. Concerns were raised around significant weather events in Ngaruawahia and what implications this might have on the safety of Ngaruawahia residents.
- Further concerns raised around Motorbike riders around town and the havoc this was creating for residents.
- Daffodil Day Planting – Council have been in touch to get this going by the end of April/early May (planting). Council would look at connecting with schools to take part in the planting and they are wanting to plant 4000 bulbs again.
- Housing stocks around New Zealand: Recent events highlight building that is happening and infrastructure to support the building. Good proactive work being done by Council getting out ahead of the cyclone to clear drains.
- Acknowledgement of Emergency Operating Centre and Council staff around Cyclone Gabrielle.

- There was good traffic flow on the Raglan diversion through Waingaro Road.
- A big Thank you to Ms Firth for organising the Christmas break up with Taupiri Community Board.
- Ngaruawahia Pools Community Event date: The board would look at pushing this to the end of March 2023 before the Pound Pool Pups event.
- Te Awa Cycleway opening at the end of March: All community groups have been asked to be involved in the day. A date for the event will be confirmed along with an outline as to what is happening on the day.
- Directional Signs for the Ngaruawahia Pools went up yesterday.

ACTION: The Board to arrange to invite Ngaruawahia Community Police or Community Constable to the next workshop or Board meeting to discuss community safety and in particular the Motorbike riders in town.

Additional Works & Issues Update from Community Led Development Advisor

Mrs L Van Den Bemd spoke to the Blueprint project and beautification of Ngaruawahia.

- Roller door project is being look at as well as other projects.
- The Board along with the Community Led Development Team can look at doing an exercise/workshop day with members of the community to look at different projects that can be done to beautify Ngaruawahia.
- Look at involving Citycare, Twin River Arts, The marae and other members of the community.
- There was a small budget from the Blueprint funds that could be used to kick-start the project.
- The art teacher at Ngaruawahia High was keen to work on the roller doors with students.
- Put out up to date messages to the community around Community Led Development.
- Community Led Development are keen to workshop this further with the board to nut out the details along with leaders in the community and sports clubs.
- The Waikato Bridge work by the Alliance Team has been delayed but could be a project that the board picks up especially if traffic management is already in place – could easily make a day of it.
- Look at scheduling a workshop for March after the Turangawaewae Poukai and Regatta.
- Te Mana o Te Rangi reserve: there were no concerns from Great South Road residents around the reserve.
- Food Bank & community involvement was going well.

ACTION: Community Led Development Advisor to work with the Board on the Blueprint Project and attend workshop which is scheduled for March.

- Internet link between Police and Ngaruawahia Community House: a quote has been provided to the Board by Cornerstone Security. Cr Patterson would liaise with Ms M May (Deputy General Manager – Service Delivery) to follow this up further. It would be picked up at the next meeting/workshop.

There being no further business the meeting was declared closed at 7.37PM.

Minutes approved and confirmed this day of 2023.

K Morgan
CHAIRPERSON

To	Ngaruawahia Community Board
Report title	Discretionary Fund Report to 07 March 2023
Date:	28 March 2023
Report Author:	Jen Schimanski Support Accountant
Authorised by:	Alison Diaz - Chief Financial Officer

1. Purpose of the report

Te Take moo te puurongo

The purpose of this report is to update the Ngaruawahia Community Board on the Discretionary fund spend to date, commitments and balance as at 07 March 2023.

2. Staff recommendations

Tuutohu-aa-kaimahi

THAT the Ngaruawahia Community Board;

- a. receives the report;**
- b. approves an allocation of \$2,950.00 from their Discretionary Funding account to:**
 - i. Ngaruawahia RSA Memorial Club Incorporated;**
 - ii. for Anzac Day commemorations and the erection of the White Crosses.**

3. Attachments

Ngaa taapirihanga

Attachment 1 – Discretionary Fund report to 07 March 2023.

Attachment 2 – Application for Funding (Ngaruawahia RSA Memorial Club Inc.)

Attachment 3 – Funding Application Flag Quote (Ngaruawahia RSA Memorial Club Inc.)

NGARUAWAHIA COMMUNITY BOARD DISCRETIONARY FUND REPORT 2022/23 (July 2022 - June 2023)
As at Date: 07-Mar-2023

				GL 1.205.1704
2022/23 Annual Plan				20,999.00
Carry forward from 2021/22				92,372.00
Total Funding				<u><u>113,371.00</u></u>
Income				-
Total Income				<u><u>-</u></u>
Expenditure				
18-May-22	Payment of \$2,750.00 (incl. GST) towards the cost of building improvement for Hope Rising Farm Trust transfer from the Te Mana O Te Rangi Reserve Commitment	NCB2205/04		2,750.00
05-Jul-22	Payment of \$3,130.00 (excl. GST) to Te Whare Toi O Ngaaruawaahia towards the cost of the Matariki Festival transfer from the Te Mana O Te Rangi Reserve Commitment	NCB2206/04		3,130.00
07-Nov-22	Payment of \$2,549.50 (inc. GST) to Belgravia Leisure towards the cost of it's local swimming programme for the 2021 - 2022 season from the Discretionary Fund	NCB2210/09		2,216.96
11-Nov-22	Payment of \$2,482.06 (excl. GST) to the Ngaruawahia Community House towards the cost of the 'Shot Bro' performance in Ngaruawahia from the Discretionary Fund	NCB2210/08		2,482.06
15-Nov-22	Payment of \$4,000.00 (excl GST) to Ngaruawahia Community Patrol for repairs and maintenance to patrol car and insurance/gas costs.	NCB2209/04		4,000.00
Total Expenditure				<u><u>14,579.02</u></u>
Net Funding Remaining (Excluding commitments)				<u><u>98,791.98</u></u>
Commitments				
13-Nov-18	Te Mana o Te Rangi Reserve - includes \$500 commitment for an opening ceremony (NCB1906/04). 08/09/20 Commitment increased by \$20,000 (NCB2009/04)	NCB1811/04 NCB1906/04 NCB2009/04	40,000.00	
22-Mar-22	Less Payment \$2,750.00 (excl GST) towards the installaiton of ANZAC Street Flags from Te Mana o Te Rangi Reserve	NCB2202/03	(2,750.00)	
03-May-22	Less Commitment of \$2,750 (incl. GST) towards the cost of building improvement for Hope Rising Farm Trust transfer from the Te Mana O Te Rangi Reserve Commitment	NCB2205/04	(2,391.30)	
14-Jun-22	Less Commitment of \$3130 (excl. GST) to Te Whare Toi O Ngaaruawaahia towards the cost of the Matariki Festival transfer from the Te Mana O Te Rangi Reserve Commitment	NCB2206/05	(3,130.00)	31,728.70
04-Nov-19	Ngaruawahia Railway Bridge commitment: 50% subsidy of Ngaruawahia pool 18/19 (NCB1811/04) & 19/20. (NCB1911/09) & 21/22 (NCB2111/05)	NCB1811/04 NCB1911/09 NCB2111/05	10,000.00	
	Less : Payments made to Belgravia Leisure for Pool Admissions (23/01/2020)		(1,309.74)	
	Less : Payments made to Belgravia Leisure for Pool Admissions (28/02/2020)	NCB2006/04	(903.97)	
	Less : Payments made to Belgravia Leisure for Pool Admissions (26/03/2020)	NCB2002/01	(334.78)	
	Less : Payments made to Belgravia Leisure for Pool Admissions (12/04/2022)	NCB2210/09	(2,216.96)	5,234.55
01-Dec-20	Allocation of \$2,000 to the Ngaruawahia High School towards the costs relating to the Ngaruawahia Dog Agility Park project. Funds from the discretionary fund will be utilised for the installation of equipment at the Dog Agility Park.	NCB2012/03		2,000.00
15-Jun-21	Commitment of \$25,000 allocated to an ongoing Security Project in Ngaruawahia	NCB2106/04		25,000.00
22-Feb-22	Commitment to Camera Licensing Trust of \$20,000 (excl GST) towards the cost of Security Camera Project in Ngaruawahia	NCB2202/05		20,000.00
26-Jul-22	Commitment of \$5,000 (GST exclusive) to Ngaruawahia Bowling Club for remedial repairs	NCB2207/06		5,000.00
Total Commitments				<u><u>88,963.25</u></u>
Net Funding Remaining (Including commitments)				<u><u>9,828.73</u></u>

From: webadmin@waikatodc.govt.nz
To: [Democracy](#)
Subject: New form response
Date: Thursday, 16 March 2023 3:00:33 pm

Sitefinity Logo



New form response

Form: [Community Board/Committee Funding Application Form](#)

A new response was submitted on 16 March 2023.

Select your Community Board or Committee	Ngaruawahia
Name of your organisation and contact person	Ngaruawahia RSA Memorial Club Incorporated
What is your organisation's purpose/background	The Ngaruawahia RSA provides comfort and support not only to service personnel and their families as well as providing a facility that is a safe welcoming place for service personnel and their families as well as the extended community to meet and interact through a variety of activities. The Ngaruawahia RSA also remembers those who have fought and lost their lives for New Zealand with events such as ANZAC Day, Armistice, White Crosses etc..
Phone number	0210535848
Email	anner@ngacomhouse.org.nz
What is your event / project, including date and location?	ANZAC Day commemorations and the erection of the White Crosses. In early April flags are erected on Great South road through Ngaruawahia as a visual reminder to all of those who have served for their country
How will the wider community benefit from this event/project?	The Ngaruawahia community embraces ANZAC Day commemorations, this is judged by the number of the community who attend the laying out of the White Crosses at Te Mana o te Rangi Reserve approximately 120 in 2022, Dawn Service at Te Mana o te Rangi on ANZAC Day approx 300 -2022, Civic Service and laying of wreaths at the Cenotaph, then refreshments hosted at the Ngaruawahia RSA approximately 500 attended
Are you GST registered?	Yes (Do NOT include GST in your budget)
GST Number	86537796
What is the total cost of your project/event	\$2950 + gst
Existing funds available for the project. Include any projected income i.e. ticket sales, merchandise etc.	NA
Project Breakdown (itemised costs of funding being sought)	Flag quote 2023.pdf
Has/will funding been sought from other funders?	No

If 'Yes', please list the funding organisation(s) and the amount of funding sought	
Describe any donated material / resources provided for the event/project	We have a pool of 40 volunteers who assist during April with erecting of the White Crosses, Dawn Service on ANZAC Day and kai for the community after the Civic Service on ANZAC Day. Support from both Kaumatua and a Minister for ceremony around erecting the crosses, Dawn Service on ANZAC Day. Community members donate towards providing kai.

[View response](#)

**Facsimile Transmission****Tree Power Ltd**

Felling, Pruning, Trimming, Shaping,
 Tree clearance from power & phone service.
 P.O. Box 20193, Te Rapa, Hamilton
 Telephone 0-7-856 8887 Mobile 0274 929 514

Qualified Linesmen & Arborists

12 Metre Cherry Picker

Date: 15.03.23

Attention: Anne Ramsay.

Company: Nga RSA Memorial Club Incorporated.

Telephone: 8248340

Email #: anner@ngacomhouse.org.nz

Subject: Anzac flag hanging/removal.

Sender: Warren Allen (Possum.)

Sender Telephone #: 0-7 856 8887

Sender Fax #: 0-7 856 3338

You should receive 1 page, including this cover sheet.. If you do not receive all the pages, please call the number above.

THIS FACSIMILE MESSAGE AND ACCOMPANYING DATA MAY CONTAIN INFORMATION THAT IS CONFIDENTIAL AND SUBJECT TO LEGAL PRIVILEGE. IF YOU ARE NOT THE INTENDED RECIPIENT, YOU ARE NOTIFIED THAT ANY USE, DISSEMINATION, DISTRIBUTION OR COPYING OF THIS MESSAGE DATA IS PROHIBITED. IF YOU HAVE RECEIVED THIS FACSIMILE IN ERROR, PLEASE NOTIFY ME IMMEDIATELY AND RETURN THE FACSIMILE TO ME. THANK YOU

Thank you for the opportunity to submit a quote for work as follows:-

Location. Ngaruawahia Great South road.

Job Description. Hanging & removal of approx 47 Anzac flags on poles two men 12m cherry picker

Price to complete \$2,950+GST

Ref no. 051493

Should you any further queries please feel free to contact me
 W S Allen (Possum) Managing Director

Tree work is carefully carried out by:-

- Specially trained Contractors equipped with fully insulated 12m Cherrypicker, Wood Chipper, modern specialised tree pruning and felling equipment & techniques
 Qualified Arborist - Full insurance cover (\$2,000,000).

To	Ngaruawahia Community Board
Report title	Works, Actions & Issues Report: Status of Items March 2023
Date:	28 March 2023
Report Author:	Karen Bredesen - EA to the General Manager Service Delivery
Authorised by:	Kurt Abbott - Executive Manager, Projects & Innovation

1. Purpose of the report

Te Take moo te puurongo

To update the Ngaruawahia Community Board on actions and issues arising from the previous meeting and works underway in March.

2. Staff recommendations

Tuutohu-aa-kaimahi

THAT the Ngaruawahia Community Board Works, Actions & Issues Report: Status of Items for March 2023 be received.

3. Attachments

Ngaa taapirihanga

Attachment 1 – Ngaruawahia Community Board Works, Actions & Issues Register – March 2023

Ngaruawahia Community Board Actions – March 2023

	Actions	To Action	Update/Response
1.	<p>Street Names Ms E Wilson to provide an updated report to the Board of the full list of street names over the last 3 years and the history of approved names and where the approved names are now being used.</p> <p>February 2023 Update: A workshop is to be organised with the Board and Roothing Team for later on in 2023 to look at more street names for the Ngaruawahia approved list.</p>	Roothing, Ellen Wilson	<p>The Ngaruawahia Community Board will have a workshop this year to select more names for the pre-approved road name list. The names in this report that can be added to the pre-approved road name list will form part of the Board's workshop.</p> <p>A review of the Waikato District Council Road Naming Policy is also being undertaken in 2023 to improve the Road Naming process.</p> <p><u>Attachments:</u></p> <ul style="list-style-type: none"> • Attachment 1 – NCB approved road names 2016 – 2022 • Attachment 2 – NCB pre-approved road name list with names used • Attachment 3 – 2015 list of approved and suggested NCB names – not on current list <p>March 2023: The Team will contact the Board Chair by the end of April to organise a suitable time to schedule the workshop.</p>
2.	<p>Community Safety The Board to arrange to invite Ngaruawahia Community Police or Community Constable to the next workshop or Board meeting to discuss community safety and in particular the Motorbike riders in town.</p>	Democracy/The Board	<p>March 2023: The Community Constable is not available on 28 March so he has been invited to the NCB workshop on the 21st March 2023.</p>

	Actions	To Action	Update/Response
3.	Blueprint Project Community Led Development Advisor to work with the Board on the Blueprint Project and attend workshop which is scheduled for March.	Community Led Development Advisor	March 2023: The Community Led Development Advisor, Lianne van den Bemd, will be attending the workshop on 21 st March to discuss the Blueprint project.

Ngaruawahia Works (As of 13 March 2023)

Perry Bridge Lighting – Power System Replacement

Discussions with the lighting system supplier/installer are ongoing.

Ngaruawahia Hall

Staff are working with GDC consultants to have the building consent application submitted for the new accessibility toilet and the statement of works.

Sportsfield Lighting – Paterson Park

A planning assessment by Potentialis consultants is complete and will provide a summary of options to ensure compliance of the new training lights with district and regional requirements.

Ngaruawahia Aquatic Centre

Development of a concept design for a pedestrian entrance off Market Street is continuing.

Panthers League Ground Carpark

A resource consent has been submitted to WDC through Gray Matter consultants.

BCD consultants are undertaking geotech, site survey, and service location and will then carry out detailed design.

To	Ngaruawahia Community Board
Report title	Proposed Road Names for Subdivision 0013/21 at 24 Jackson Street, Ngaruawahia
Date:	28 March 2023
Report Author:	Ellen Wilson, Contracts & Compliance Coordinator
Authorised by:	Megan May General Manager Service Delivery

1. Purpose of the report

Te Take moo te puurongo

To seek approval from the Ngaruawahia Community Board on the Proposed Road Name for Subdivision 0013/21 at 24 Jackson Street, Ngaruawahia.

2. Executive summary

Whakaraapopototanga matua

This report requests that the Ngaruawahia Community Board approve the attached proposed road name for this subdivision at 24 Jackson Street, Ngaruawahia. The name Tāpapa Lane has been proposed by the developer outside the pre-approved list. It is supported by the local hapuu Nga Uri o Tamainupo ki Whaingaroa Trust and by Council's roading team.

The name has been checked by Council staff against the Road Naming Policy.

3. Staff recommendations

Tuutohu-aa-kaimahi

THAT the Ngaruawahia Community Board;

- a. approves the following proposed road name submitted by the developer for SUB 0013/21 at 24 Jackson Street, Ngaruawahia.**
 - **Road 1 (B) – Tāpapa Lane**
-

4. Background

Koorero whaimaarama

SUB 0013/21 is a residential development on, more or less, 8253m² at 24 Jackson Street, Ngaruawahia. The development is consented to create 6 new lots situated on the southern side of Jackson Street in Ngaruawahia.

While a pre-approved list of names exists for the Ngaruawahia Community Board (attached), the developer is permitted to go outside of this list and propose different names. This is contemplated in the Road Naming Policy under section 1.2 as follows:

1.2 Request for Road Name not from the "Approved List" of Road Names

(a) Where an "Approved List" is not available or the subdivision developer wishes to choose their own road names, the developer shall make a request to Council's Roading Asset Team.

As required by the Road Naming Policy, the Developer has consulted with local hapuu Nga Uri o Tamainupo ki Whaingaroa Trust who chose this name. Tāpapa means Garden bed for kūmara plants. Due to its proximity to Pukeiāhua Pā, this area would have been covered in Kūmara gardens in the 1700s. Pukeiāhua Pā is an important site for Ngaruawahia, as it features in the story of how Ngaruawahia got its name.

Staff have reviewed the name and considered it does not duplicate, sound too similar, or is a duplicated street type (e.g. street, road, avenue, boulevard, junction, crescent, etc) which may otherwise cause travel uncertainties in the Waikato District. The names have been checked against Google mapping and NZ Post.

Hamilton City Council has confirmed that there is no similar sounding name within their District which would otherwise cause confusion. Staff note the only similar name is Tapapa Road in Tirau which is outside the LINZ addressing standards required distance.

5. Discussion and analysis

Taataritanga me ngaa tohutohu

The table below provides a list of recommended historical, social, cultural and geographic themed names, background to the name choice, an indication of any potential duplication or sound similarity issues, and the exclusion of any suffix if applicable as per Road Naming Policy.

Name (in order of preference)	Reason	Location of duplicate or similar sounding name in adjoining councils	OFFICE USE ONLY	
			Classification Exclusion and notes	Approved or Declined
Tāpapa Lane	Tapapa means Garden bed for kūmara plants. Due to its proximity to Pukeiāhua Pā, this area would have been covered in Kūmara gardens in the 1700s. Pukeiāhua Pā is an important site for Ngaruawahia, as it features in the story of how Ngaruawahia got its name.	I. Tapapa Road – over 86km away	nil	Approved by roading team

5.1 Options

Ngaa koowhiringa

Staff have assessed that there are two reasonable and viable options for the Community Board to consider:

- 1) Option 1 – approve the requested road names.
- 2) Option 2 – require the developer to use names only from the approved list.

Staff recommend option 1, approving the road name application as the ability to use alternative names is contemplated by the policy, and the name has been put forward with local hapuu support.

5.2 Financial considerations

Whaiwhakaaro puutea

There are no material financial considerations associated with the recommendations of this report. All costs for new road names are being met by developers.

5.3 Legal considerations

Whaiwhakaaro-aa-ture

Staff confirm that the staff recommendation complies with the Council's legal and policy requirements.

5.4 Strategy and policy considerations

Whaiwhakaaro whakamaaherehere kaupapa here

The report and recommendations are consistent with the Council's policies, plans and prior decisions.

5.5 Maaori and cultural considerations

Whaiwhakaaro Maaori me oona tikanga

Local hapuu have been included in the correspondence to the necessary community committee members advising of the road name application.

5.6 Climate response and resilience considerations

Whaiwhakaaro-aa-taiao

The matters in this report have no known impact on climate change or resilience for the Council.

5.7 Risks

Tuuraru

The decisions and matters of this report are assessed as of low risk, in accordance with the Council's Risk assessment and risk appetite.

6. Significance and engagement assessment

Aromatawai paahekoheko

6.1 Significance

Te Hiranga

The decisions and matters of this report are assessed as of low significance, in accordance with the Council's [Significance and Engagement Policy](#).

6.2 Engagement

Te Whakatuutakitaki

Highest level of engagement	Inform <input type="checkbox"/>	Consult <input checked="" type="checkbox"/>	Involve <input type="checkbox"/>	Collaborate <input type="checkbox"/>	Empower <input type="checkbox"/>
<i>Tick the appropriate box/boxes and specify what it involves by providing a brief explanation of the tools which will be used to engage (refer to the project engagement plan if applicable).</i>	Consultation has occurred via the developers engagement with local hapuu Nga Uri o Tamainupo ki Whaingaroa Trust. Council staff have also engaged with neighbouring councils to determine any conflict of names.				

State below which external stakeholders have been or will be engaged with:

Planned	In Progress	Complete	
<input type="checkbox"/>	<input type="checkbox"/>	<input type="checkbox"/>	Internal
<input type="checkbox"/>	<input checked="" type="checkbox"/>	<input type="checkbox"/>	Community Boards/Community Committees
<input type="checkbox"/>	<input type="checkbox"/>	<input checked="" type="checkbox"/>	Waikato-Tainui/Local hapuu Nga Uri o Tamainupo ki Whaingaroa Trust.

Planned	In Progress	Complete	
<input type="checkbox"/>	<input type="checkbox"/>	<input type="checkbox"/>	Affected Communities
<input type="checkbox"/>	<input type="checkbox"/>	<input type="checkbox"/>	Affected Businesses
<input type="checkbox"/>	<input type="checkbox"/>	<input type="checkbox"/>	Other (Please Specify)

7. Next steps Ahu whakamua

The approved report and associated road name list will be presented to the subsequent Infrastructure Committee meeting.

If the preferred name is approved, the Developer will utilise this. If not, an alternative option will be used.

8. Confirmation of statutory compliance Te Whakatuuturutanga aa-ture

As required by the Local Government Act 2002, staff confirm the following:

The report fits with Council's role and Ngaruawahia Community Board's Terms of Reference and Delegations.	Confirmed
---	-----------

The report contains sufficient information about all reasonably practicable options identified and assessed in terms of their advantages and disadvantages (<i>Section 5.1</i>).	Confirmed
--	-----------

Staff assessment of the level of significance of the issues in the report after consideration of the Council's Significance and Engagement Policy (<i>Section 6.1</i>).	Low
---	-----

The report contains adequate consideration of the views and preferences of affected and interested persons taking account of any proposed or previous community engagement and assessed level of significance (<i>Section 6.2</i>).	Confirmed
---	-----------

The report considers impact on Maaori (<i>Section 5.5</i>)	Confirmed
--	-----------

The report and recommendations are consistent with Council's plans and policies (<i>Section 5.4</i>).	Confirmed
---	-----------

The report and recommendations comply with Council's legal duties and responsibilities (<i>Section 5.3</i>).	Confirmed
--	-----------

9. Attachments

Ngaa taapirihanga

Attachment 1 – Development Road Map

Attachment 2 – Ngaruawahia pre-approved road name list

Amalgamation Condition
 That Pursuant to Section 220(1)(b)(iv) of Resource Management Act 1991. That Lot 12 hereon (Legal Access) be held as to 6 one sixth shares by the owners of lots 5-10 as tenants in common in the said shares and that individual certificates of title be issued therewith.
 See LINZ Request

Memorandum of Easements to Close			
Easement	Servient Tenement (Overhead Land)	Dominant Tenement (Benefited Land)	Created by
Right to convey sewage / Right to water	X	Lot 12	Waikato District Council
Right to convey sewage	C	Lot 5	Waikato District Council
Right to drain water	E	Lot 7	Waikato District Council
Right to drain water	F	Lot 10	Waikato District Council
Right to drain water	G	Lot 10	Waikato District Council
Right to drain water	H	Lot 9	Waikato District Council

PLANS
 13/21
 y: Nicola Laurenson - Laurenson Planning
 ember 2021
CONSTRUCTION

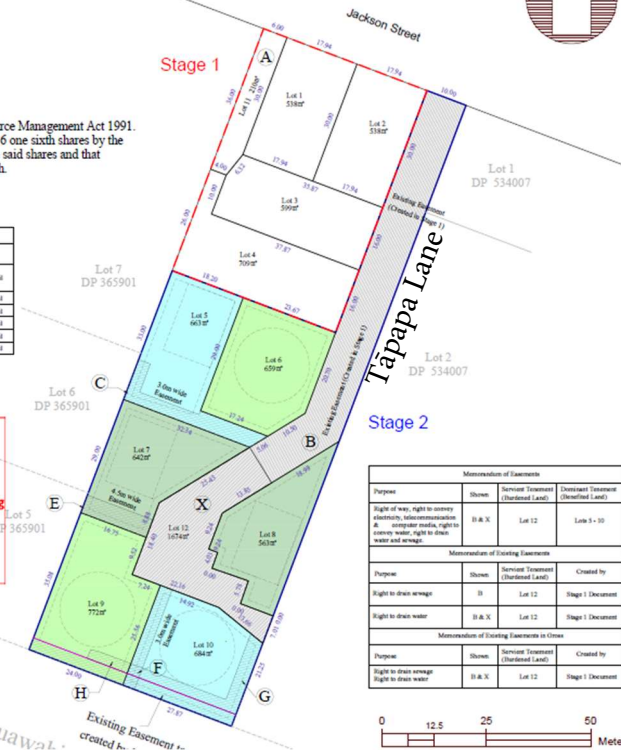

Memorandum of Easements			
Purpose	Share	Servient Tenement (Overhead Land)	Dominant Tenement (Benefited Land)
Right of way, right to convey electricity, telecommunication & computer media, right to convey water, right to drain water and sewage.	B & X	Lot 12	Lots 5 - 10

Memorandum of Existing Easements			
Purpose	Share	Servient Tenement (Overhead Land)	Created by
Right to drain sewage	H	Lot 12	Stage 1 Document
Right to drain water	B & X	Lot 12	Stage 1 Document

Memorandum of Existing Easements to Close			
Purpose	Share	Servient Tenement (Overhead Land)	Created by
Right to drain sewage	B & X	Lot 12	Stage 1 Document
Right to drain water	B & X	Lot 12	Stage 1 Document

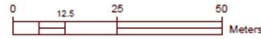

REVISED				DATE
DRAWN				29/NOV/2021
TRACED				
CHECKED				
REVISION	CHANGES	APPROVED	DATE	
NOTES				
Zoning - General Residential Zone Waikato District Operative District Plan Legal Description - Lot 4 DP5 76141 Total Area = 9253sq Computed in CT - SA60C129				
Stage 2				
Lot 100 to be created as part of Stage 1 Subdivision				
CLIENT				
Dave Cooper				
PROJECT				
24 Jackson Street Ngaruawahia				
TITLE				
Preliminary Plan of Subdivision Lots 5 - 10 & 12 a Subdivision Lot 100 DP				
GEOTEC LOW Ltd				
SURVEYORS TOWN PLANNERS RESOURCE MANAGEMENT CONSULTANTS 26 Kelvin Place, Hamilton East, Hamilton TEL: 07 858 9568 Email: info@geotec.co.nz				
The copyright of this design and drawing is vested in GEOTEC LOW Ltd unless otherwise indicated				
The scale is 1 in 750 (A3 size)				
DRAWING NO.				REVISION

ID	Name	Reason	Location of duplicate or similar sounding name in NZ	Classification exclusions and notes
<u>Noteworthy Persons</u>				
	Morse	Morse family are long-time Ngaruawahia residents. Allan Morse was a Waikato DC Councillor for many years.	Napier, Christchurch	Seek Allan's permission
	Haggie	The Haggie whanau are long-time Ngaruawahia residents associated with the establishment of Turangawaewae Marae. The Haggie whanau were and still are active in town sports, especially rowing and rugby league.		Turangawaewae Marae asks that permission is sought from whanau.
	Tahapeehi	The Tahapeehi whanau are long-time residents of Ngaruawahia, still residents today and associated with the establishment of Turangawaewae Marae. This whanau was and still are very active in sports in the town, especially Rugby league.		Turangawaewae Marae asks that permission is sought from whanau.
	McBurney	Famous sporting family of Ngaruawahia, particularly rowing and horse racing	Mangere East, Auckland	Exclude title "place". Obtain family agreement.
<u>Astrological themed names</u>				
	Te Kokota	Hyades: the nearest open cluster to the Solar System in Greek mythology, the Hyades were the five daughters of Atlas and half-sisters to the Pleiades. After the death of their brother, Hyas, the weeping sisters were transformed into a cluster of stars that was afterwards associated with rain.		

ID	Name	Reason	Location of duplicate or similar sounding name in NZ	Classification exclusions and notes
<u>Ngaruawahia Native Plants</u>				
	Hangehange	Grows locally. Geniostema ligustrifolium.	None.	
	Panakenake	Common name - Pratia. Grows locally. Lobelia angulata.	Way – Flat bush, Auckland	Exclude “Way”
	Parataniwha	Common name – NZ begonia. Grows locally.	None	
	Pate	Common name – Seven finger. Grows locally. Also known as Patete by Tainui.	Crescent – Favona, Auckland	Exclude “Crescent”
	Pohuehue	Common name – Large leaved muehlenbeckia. Grows locally.	Lane – Papakura, Auckland Suburb – Warkworth	Exclude “Lane”
	Puawhananga	Common name – White clematis. Grows locally.	None.	
	Wiwi	Knobby club rush. Grows locally.	None	

To	Ngaruawahia Community Board
Report title	Infrastructure Acceleration Fund, Festival Way / Galbraith Street
Date:	Tues 14th Feb
Report Author:	Will Gauntlett, Patrick Edwards – Growth & Analytics Manager
Authorised by:	Roger MacCulloch - General Manager Service Delivery

1. Purpose of the report

Te Take moo te puurongo

To inform the Board of the successful \$5.3M Infrastructure Acceleration Fund (IAF) Government grant funding to enable infrastructure and housing delivery in and around Festival Way in Ngaruawahia.

To introduce the Project Manager to the Board and to open the dialog between the staff team and the Board, including sharing concept plans for feedback and sharing a high-level programme for the works.

2. Executive summary

Whakaraapopotanga matua

Next Construction Limited (Next), a private development company managing significant landholdings in Ngaruawahia, has been successful in an application to the Government's Infrastructure Acceleration Fund (IAF).

The \$5.3M grant funding is to construct key enabling infrastructure around Festival Way. The bulk of the funding is for roading and stormwater infrastructure and will enable the development of over 200 houses.

The residentially zoned catchment currently faces infrastructure constraints, and is in fragmented ownership. Residential development would continue to be slow without local or central government assistance.

Council supported Next's application providing a letter of support and help with technical input into the funding application. The application as also supported by Taangata Whenua.

Kāinga Ora's commercial arm is administering the fund. The IAF requires a Funding Agreement between Council and Kāinga Ora. The Agreement obligates Council to deliver the infrastructure by certain milestone dates. There is also a Housing Outcomes Agreement between Council, Kāinga Ora and Next, to ensure delivery of houses by milestone dates and to deliver 20% of that stock below \$750,000.

Council has engaged Patrick Edwards from Development Partners Ltd to fill the role of project manager and also CKL consultants to progress design. The initial focus is Festival Way and Galbraith Street back towards Old Taupiri Road. Wider consideration is being given to the Old Taupiri Road / Great South Road intersection, an upgrade of which is also included in the funding package. Concept design options for Festival Way have been prepared and are attached to this report at Attachment 1.

The IAF funding is a capped funding bucket. If there are cost overruns they need to be funded by Council. It is Council's intention to utilise Development Agreements and Development Contributions to recover any overruns to avoid cost impacts on rate payers at large.

3. Staff recommendations

Tuutohu-aa-kaimahi

THAT the Ngaruawahia Community Board:

- a. notes the content of the report;**
- b. notes the opportunity to engage with the project manager, including to provide input into the design and delivery processes;**
- c. advises the project manager how and when they want to be involved with the project.**

4. Background

Koorero whaimaarama

In June 2021, the Government announced the Infrastructure Acceleration Fund (IAF) initiative as part of the Housing Acceleration Fund. The \$1 bn IAF is administered by Kāinga Ora's commercial arm and aims to allocate funding to new or upgraded infrastructure to unlock housing developments in the short-to-medium term.

Next Construction Limited (Next), a private development company managing significant landholdings in Ngaruawahia, made an application to IAF to fund infrastructure in and around Festival Way. On 13 October 2022, Hon Dr Megan Woods announced that the Next application was successful.

The \$5.3M grant funding is to construct key enabling infrastructure, primarily roading and stormwater, and will enable the development of over 200 houses.

The IAF funding is to resolve the sub-catchment infrastructure constraints to enable the current development proposals to advance, and the development in the immediate term of substantially more land within the Festival Way catchment.

In addition, IAF will future proof further rezoning proposals through Medium Density Zoning (as per District Plan decisions) as well as adjoining Country Living Zone land to be considered for Residential Zoning in the future line with Waikato 2070.

Of the 200 dwellings the infrastructure enables, Next has committed to delivering at least 108. Of this, Next is committing to deliver at least 20% of those houses at a price point below the Government's First Home Grant House Price Cap for the area which is \$750,000.

The funding buckets are:

- Transport Projects \$3,561,000
- Three Waters Projects \$1,759,000
- NZTA subsidy for Festival Way and rail crossing safety improvements \$1,020,000
- Total funding \$6,340,000 (\$5.3M from IAF).

The IAF funding is for the following projects:

- Construction of Festival Way road to urban standards, including car parking
- Improvements and alterations to Galbraith Street to improve intersection and rail crossing safety
- Stormwater conveyance and treatment for Festival Way
- Stormwater conveyance for the development land
- Shared path along Festival Way and Galbraith Street to the rail crossing
- Rail pedestrian crossing rail upgrades
- Significant upgrade of the Old Taupiri Road and Great South Road intersection
- Completion of potable watermain 'loop' along Festival Way
- Upsizing a wastewater pump station to increase pumping capacity

Attached to this report as Attachment 1 is a schematic highlighting the IAF related projects.

5. Discussion and analysis

Taataritanga me ngaa tohutohu

Most of the projects are set to be delivered by December 2024 with some final road works through to March 2025.

Council has engaged consultants to progress design primarily for Festival Way and Galbraith back towards Old Taupiri Road. Concept Design options for Festival Way are included in this report at Attachment 2.

Wider consideration is being given to the Old Taupiri Road / Great South Road intersection, as part of the Ngaruawahia Structure Plan. That intersection is also included in the fund.

Conversations with Taangata Whenua are ongoing with Turangawaewae Marae, Ngaati Tamainupoo and Waikato-Tainui. WDC has engaged Te Huia Natural Resource Limited to assist with this aspect of the project, and this is building on the engagement that Next has had regarding the catchment and the IAF application.

6. Next steps

Ahu whakamua

Council's project manager will provide feedback from Next, Taangata Whenua, and the Board, alongside technical feedback, to the consultant designers to progress the design process.

The project manager is aware of the request from the Board to establish some signage in the area to communicate with the wider community about what is happening. Once initial design options have been reviewed and agreed by all parties, an information board will be erected in the area to inform the community.

The project manager can continue to engage with the Board in whatever manner it prefers.

7. Attachments

Ngaa taapirihanga

Attachment 1 – Schematic overview of IAF projects

Attachment 2 – CKL - Festival Way – Roading Concept Designs

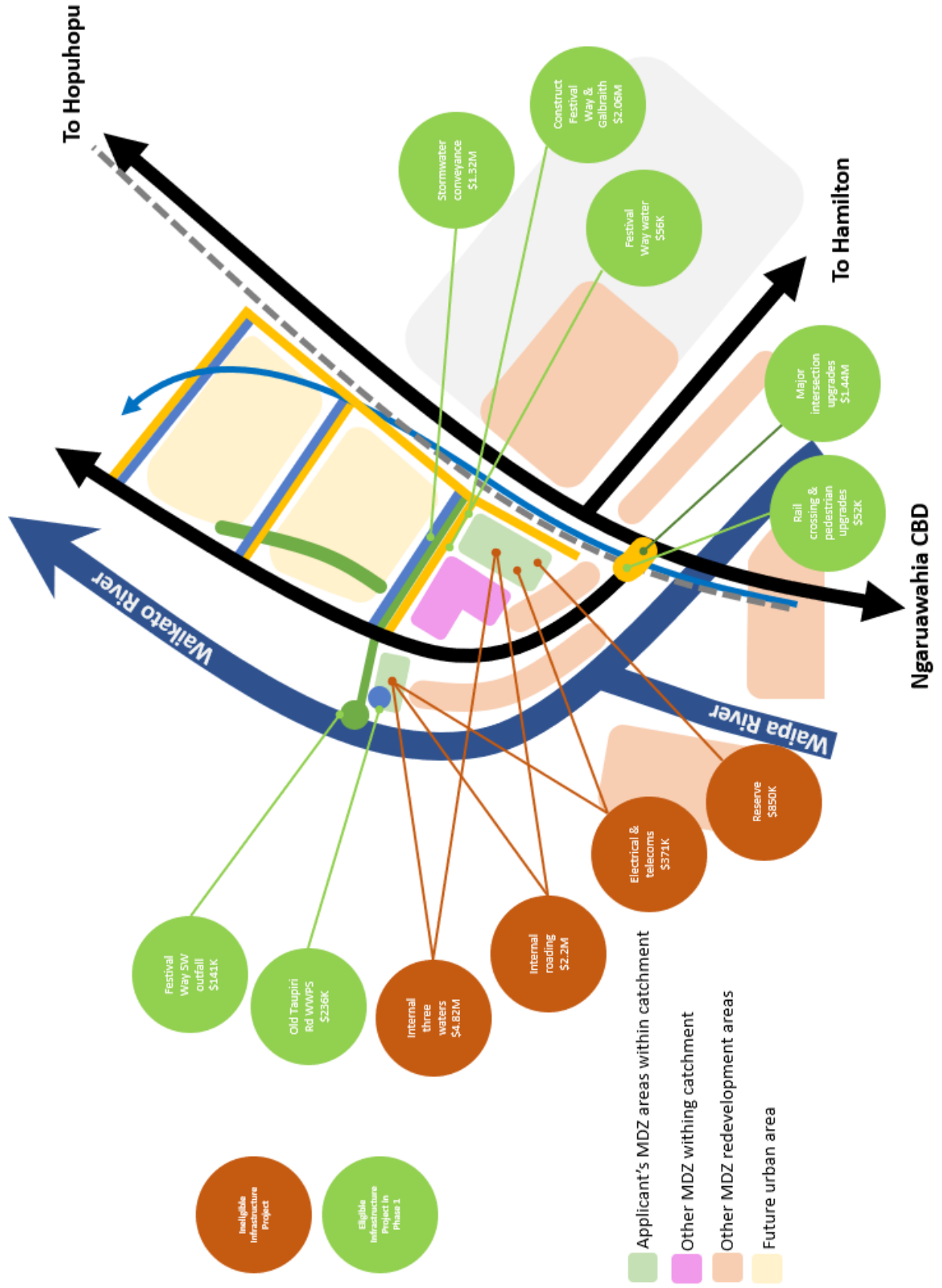

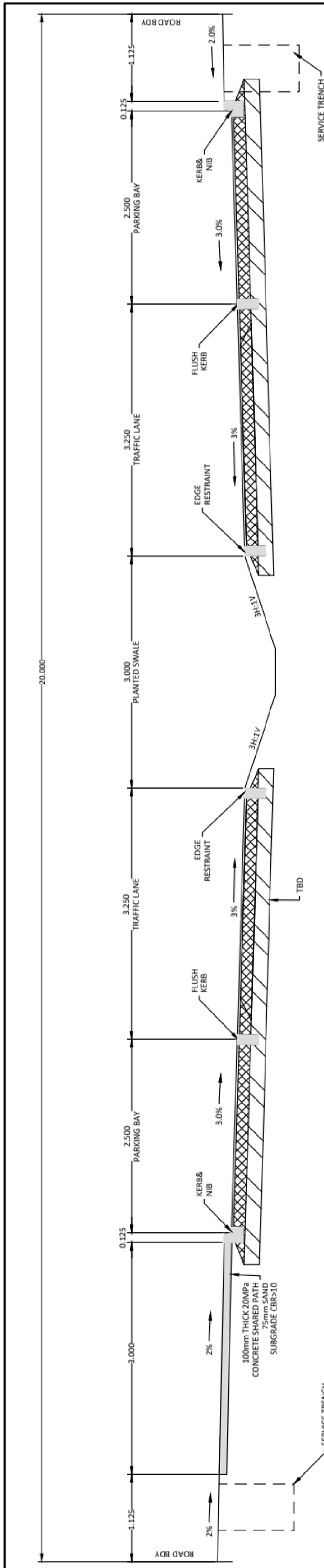

TYPICAL SECTION: FESTIVAL WAY OPTION 1 (20.0m)

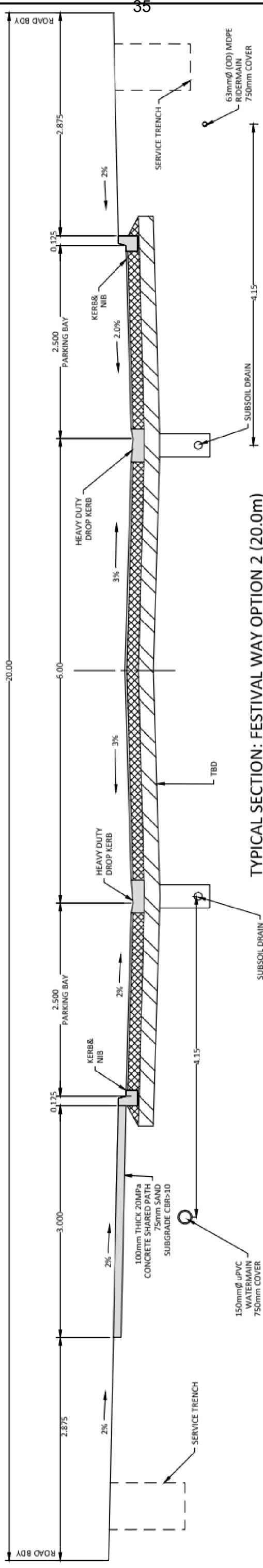

TYPICAL SECTION: FESTIVAL WAY OPTION 2 (20.0m)

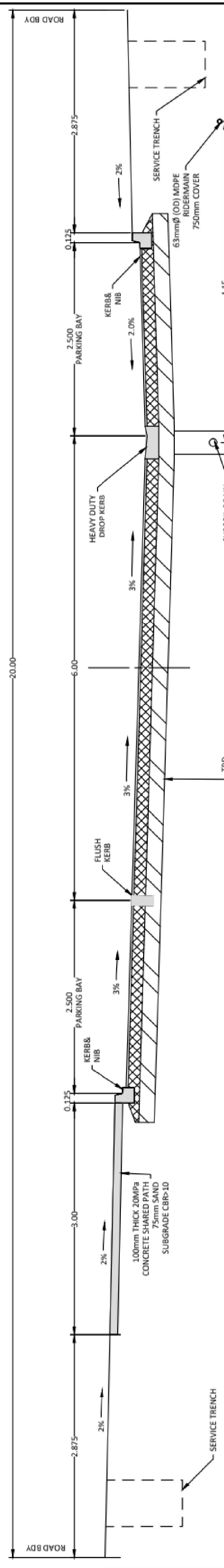

TYPICAL SECTION: FESTIVAL WAY OPTION 3 (20.0m)

CONCEPT DESIGN

Issue	Description	Checked	Date
1	FOR DISCUSSION	KG	22.12.22

Designed:	Date	Scale:
MJP	22.12.12	1:50
Drawn:	Date	
MJP	22.12.12	
Checked:	Date	
KG	22.12.16	

Job No: B20249
Dwg No: 3200
Rev: 1
(A3 Original)

FESTIVAL WAY LINK ROAD
WAIKATO DISTRICT COUNCIL
HN - FESTIVAL WAY, NGARUAWAHIA

TYPICAL ROAD
CROSS SECTIONS
SHEET 1

Office
 HAMILTON
 A: 58 Church Road, Te Rapa
 P: 07 849 9921
 E: Hamilton@ckl.co.nz

Planning | Surveying | Engineering | Environmental

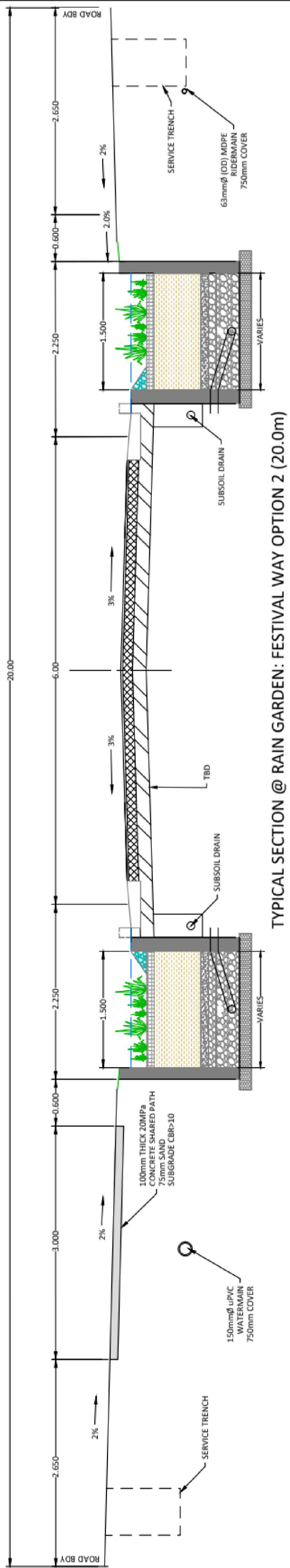

TYPICAL SECTION @ RAIN GARDEN: FESTIVAL WAY OPTION 2 (20.0m)

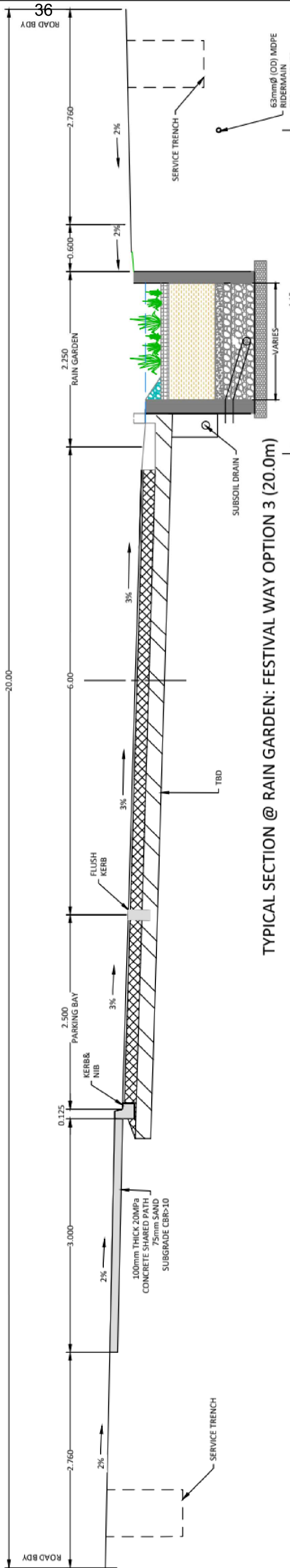

TYPICAL SECTION @ RAIN GARDEN: FESTIVAL WAY OPTION 3 (20.0m)

CONCEPT DESIGN

Issue	Description	Checked	Date	Scale:
1	FOR DISCUSSION	KG	22.12.22	1:50

Job No: B20249 3201 1
 Rev: (A3 Original)
 Dwg No: 3201 1
 Scale: 1:50

TYPICAL ROAD CROSS SECTIONS SHEET 2

**FESTIVAL WAY LINK ROAD
 WAIKATO DISTRICT COUNCIL
 HN - FESTIVAL WAY, NGARUAWAHIA**

CKL
 Planning | Surveying | Engineering | Environmental

OFFICE HAMILTON
 At: 58 Church Road, Te Rapa
 P: 07 849 9921
 E: hamilton@ckl.co.nz



Planning | Surveying | Engineering | Environmental

MEMO

APPENDIX B

LAYOUT PLAN





CONCEPT DESIGN

Issue Description	Checked	Date	Scale:
1 FOR DISCUSSION	KG	22.12.22	1:1500
			(A3 Original)
			Job No: B20249
			Dwg No: 3000
			Rev: 1

**ROAD LAYOUT
LAYOUT OVERVIEW PLAN**

**FESTIVAL WAY LINK ROAD
WAIKATO DISTRICT COUNCIL
HN - FESTIVAL WAY, NGARUAWAHIA**

OFFICE
HAMILTON
A: 58 Church Road, Te Rapa
P: 07 849 9921
E: Hamilton@ckl.co.nz

To	Ngaruawahia Community Board
Report title	Councillor’s Report – March 2023
Date:	Friday, 17 March 2023
Report Author:	Tilly Turner – Tai Runga Takiwaa Maaori Ward Councillor

1. Purpose of the report **Te Take moo te puurongo**

To provide an update on the Tai Runga Takiwaa Maaori Ward Councillor’s activities.

2. Staff recommendations **Tuutohu-aa-kaimahi**

THAT the Councillor’s Report be received.

3. Attachments **Nгаа тааpirihanga**

Attachment 1 – Councillors Report.

Ngaruawahia Community Board Report

Councillor Tilly Turner

It has been a very busy time for me, developing the Mana Whenua Forum with our Marae as well as keeping up to date with Council meetings, briefings, and workshops. Things will settle down once the Mana Whenua Forum is established. I will commit to working with these representatives within my five Wards that I share with our General elected Councillors, creating meaningful, respectful working relationships.

<u>Council Meetings:</u>	24-02	Council Meeting
	13-03	Council Meeting
<u>Sub-Committee Mtgs</u>	2-02	Maori Councillors Catch-up
	13-02	Performance and Strategy
	13-02	Tamahere Mangaone Restoration Trust
	15-02	Mana Whenua Forum
	15-02	Ngaruawahia Structure Plan Update
	17-02	Citizen Ceremony Catch-up
	21-02	Development Contributions / development Agreements
	22-02	Sustainability & Wellbeing Committee Meeting
	22-02	Trade Waste & Wastewater Bylaw Hearings & Deliberations
	23-02	Nga, HH, Taupiri Structure Plan – Urban Design Walkover
	27-02	CE Performance Review Processes and Policies
	27-02	Community Assets Induction
	27-02	Contract Management and Procurement Induction
	27-02	Reo Policy for Waikato District Council
	28-02	Waters / DIA Induction Briefing
	28-02	Roading Service and Program Induction
	28-02	Solid Waste Induction
	28-02	Capex Work Program Induction
	28-02	Rural Forum
	1-03	Infrastructure Committee
	1-03	Reference Group – NHT Structure Plan
	2-03	Mana Whenua Contacts List
	2-03	Te Awa Cycleway Opening
	6-03	Communications, Marketing & Engagement Team Induction
	6-03	Community Connections
	7-03	Policy & Regulatory Committee
	7-03	Te Whatu Ora
	8-03	Economic Development Team
	8-03	Media Training Induction
	10-03	Elected Waikato Women Social Dinner
	11-03	Maori Councillors Catch-up
	13-03	Taiao (Nature) in the Waikato Strategy
	14-03	The National Maori Housing Conference Hui
	14-03	Citizenship Ceremony

<u>Workshops</u>	13-02	Local Government Reform – Submission
	14-02	Public Places & Traffic Bylaw
	21-02	Annual Plan & Targeted Rates
	1-03	Hearings 101
	6-03	Taupiri Structure Plan and Town Centre
	7-03	Hopuhopu Structure Plan and Town Centre
	7-03	Building and Resource Consents
	8-03	Te Nehenehenui Joint Management Committee
	8-03	Ngaruawahia Structure Plan and Town Centre
	<u>Community</u>	8-02
8-02		Whatawhata Community Association Meeting
9-02		Papakainga Hui – Te Kopua Boardroom Whaingaroa
10-02		Ngati Naho – Hayden Solomon
11/12-02		Tainui Games – Mana Whenua Presentation
20-02		Taupiri Community Board Meeting
22-02		Re-scheduled Ngaruawahia Community Board
<u>Zoom</u>		9-02
	14-02	Council briefing
	14/21/28/3-03	Taamaki + Waitomo Flood Response Update Co-ordination
	15/16-02	Civil Defence Update
<u>Poukai</u>	24-11-22	Te Awamarahi – Mayor Church / Cr Keir, Reeve and Raumati
	1-01	Horahora Marae Poukai – Rangiriri
	15-01	Kokohinau Marae Poukai – Te Puke
	28-01	Taniwha Marae Poukai – Waerenga
	4-02	Hukanui Marae Poukai – Gordonton
	18-02	Maurea Marae Poukai – Rangiriri
	9-03	Paarawera Marae Poukai – Kihikihi
	25-02	Mataatini – Tribal Networking Mana Whenua
	17-03	Turangawaewae Marae Poukai – Ngaruawahia
	3-03	All Council’s Hui with Waikato Tainui at TWOW
<u>Other</u>	1-02	Taupiri Maunga – Te Puni Kokiri Karakia mo te tauhou
	3-02	Nga Marae Toopu – Mana Whenua Korero
	7-02	Te Puni Kokiri – Rangita’s Whakatau for Regional Manager
	8-02	Te Puni Kokiri – Amiria McGarvey
	20-02	Te Puni Kokiri – National Karakia Presentation
	19-02	Maori Women’s Welfare League